

S P E C I F I C A T I O N S

SMD TYPE TOP VIEW UV LED

MODEL : AU35102DFN

(Preliminary)

Dongbu LED Co., Ltd.

53-24 , Dongtansandan 6-gil , Hwaseong-si , Gyeonggi-do , Republic of Korea 18487

Tel. : +82 - 70 - 8874 - 9943 Fax. : +82 - 31 - 373 - 7626

[http : //www.dongbuled-s.com](http://www.dongbuled-s.com)

1. General Description

(1) Features

- Package size - 3.5(L) × 3.5(W) × 1.6(T) mm
- AlN ceramic substrate package
- Beam angle ($2\theta_{1/2}=120\text{deg}$)
- RoHS Compliant



(2) Applications

- Disinfection
- Fluorescence spectroscopy
- Portable sterilization
- Chemical and biological analysis

(3) Outline Dimensions

[Tolerance : ± 0.2 , unit : mm]

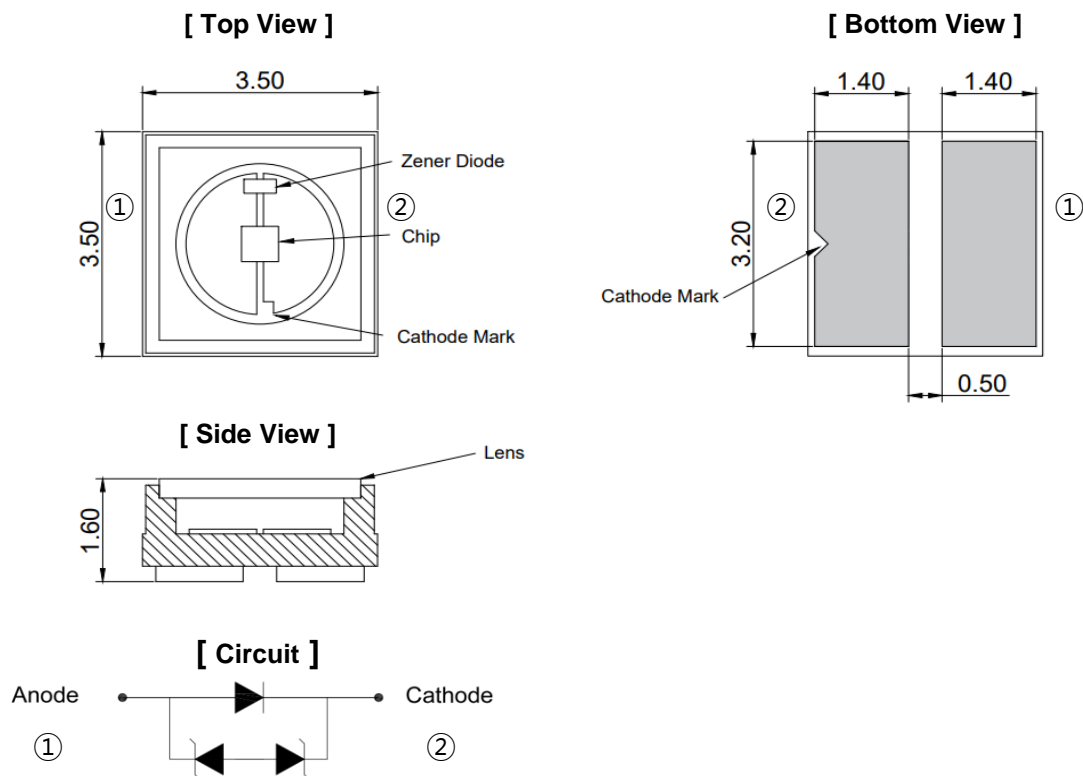

2. Specifications

(1) Absolute Maximum Ratings

 (T_a=25°C)

Parameter	Symbol	Absolute Maximum Rating	Unit	Remark
Power Dissipation	P _D	0.24	mW	
Forward Current	I _F	40	mA	
Operating Temperature	T _{OPR}	-30 to +60	°C	
Storage Temperature	T _{STG}	-40 to +100	°C	
Junction Temperature	T _J	85	°C	

(2) Initial Electrical/Optical Characteristics

 (T_a=25°C)

Parameter	Symbol	Condition	Min.	Typ.	Max.	Unit
Forward Voltage	V _F	I _F = 20mA	5.0	5.9	7.0	V
Radiant Flux	Φ _e	I _F = 20mA	-	4.0	-	mW
Peak Wavelength	λ _p	I _F = 20mA	270.0	275.0	280.0	nm
Spectrum Half Width	△λ	I _F = 20mA	-	12	-	nm
Beam Angle	2θ _{1/2}	I _F = 20mA	-	120	-	deg
Thermal Resistance	R _{θJS}	I _F = 20mA		25		°C/W

* Notes : Forward voltage measurement tolerance is ± 3%.

Radiant flux measurement tolerance is ± 10%.

Peak wavelength measurement tolerance is ± 3nm.

Initial electrical/optical characteristics data could be changeable if the user use the product in different condition besides above data.

3. Characteristics Diagrams

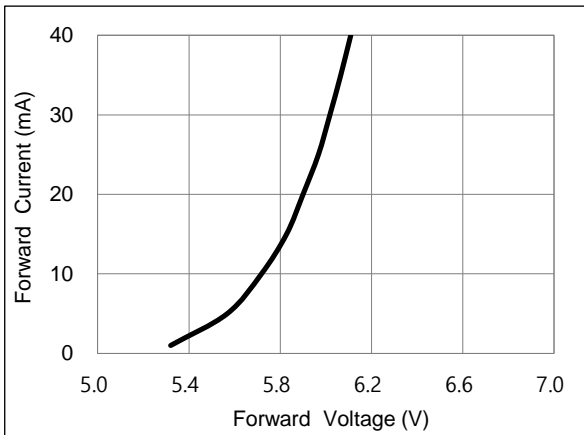

Forward Voltage vs Forward Current, $T_a=25^\circ\text{C}$

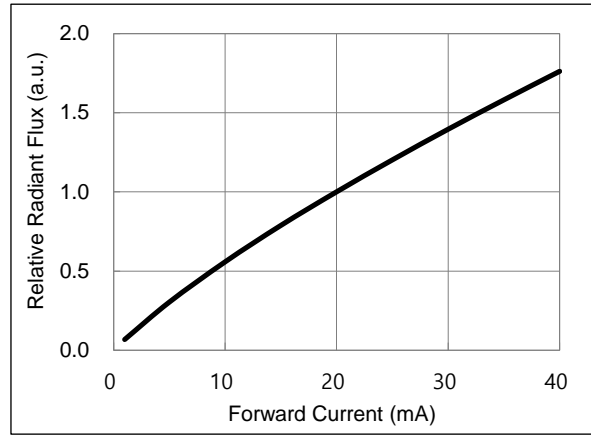

Forward Current vs Relative Radiant Flux, $T_a=25^\circ\text{C}$

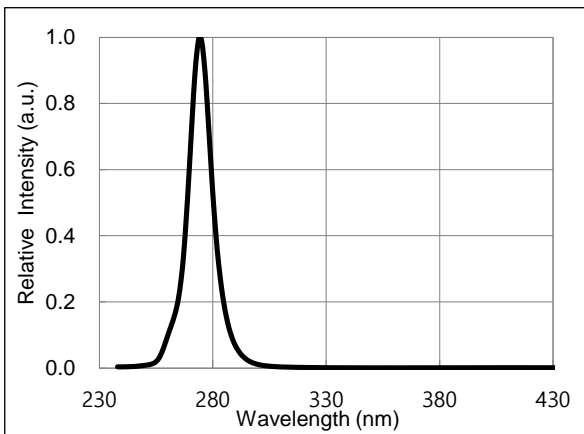

Spectrum, $T_a=25^\circ\text{C}$, $I_F=20\text{mA}$

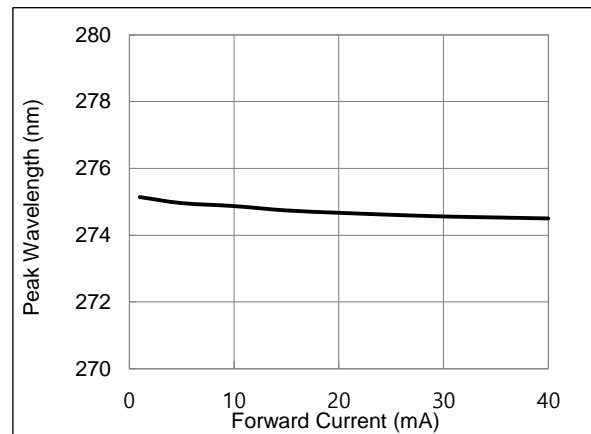

Forward Current vs Peak Wavelength, $T_a=25^\circ\text{C}$

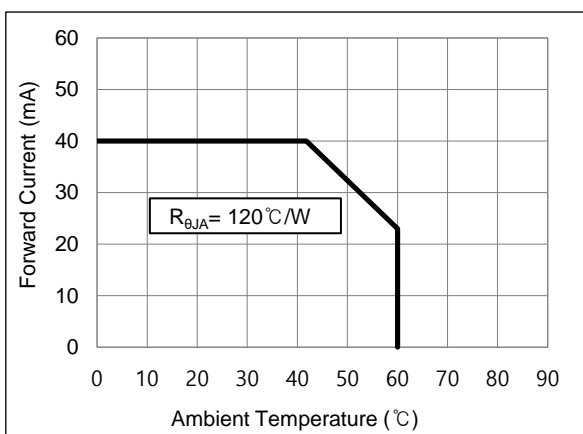

Derating Curve

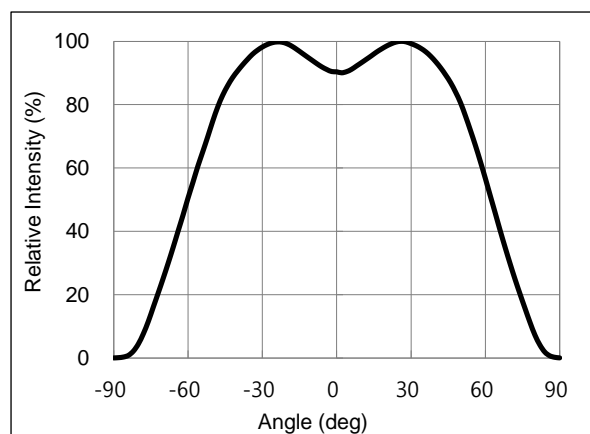

Beam Angle, $T_a=25^\circ\text{C}$, $I_F=20\text{mA}$

* Note : The graph of characteristics is the sampling data for the reference.

4. Soldering Conditions

(1) Recommended Soldering Conditions

Conditions	Reflow Soldering		Hand Soldering	
	Lead Solder	Lead-Free Solder	Temperature	Soldering Time
Pre-Heating	120 ~ 150 °C	180 ~ 200 °C		300 °C Max.
Pre-Heat Time	120sec. Max.	120sec. Max.		3 sec. Max.
Peak Temperature	240 °C Max.	260 °C Max.		(one time only)
Soldering Time	5sec. Max.	5sec. Max.		

* After reflow soldering, rapid cooling should be avoid.

(2) Recommended Reflow Soldering Profile

■ Lead Solder

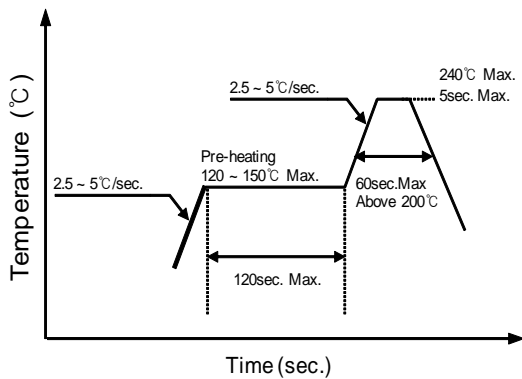

■ Lead Free Solder

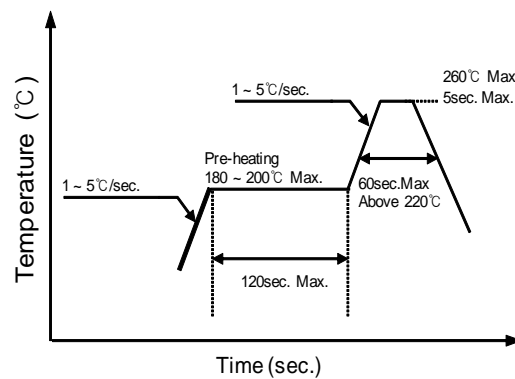

(3) Recommended Soldering Pad Pattern

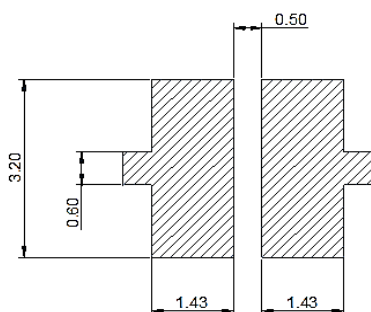

(Unit : mm)

(4) Soldering Cautions

- Reflow soldering should not be done more than two times.
- When soldering, do not put stress on the LEDs during heating.
- After soldering, do not wrap the circuit board.
- The LEDs can be soldered on place using the reflow soldering method.
- Occasionally there is a brightness decrease cause by the influence of heat or ambient atmosphere during air reflow. It is recommend that the user use the nitrogen reflow method.
- After complete soldering, the product should be handled after cooling. (required to be handled under 60 °C)

5. Packing

(1) Carrier Tape & Carrier Reel Dimensions

■ Carrier Tape

(Unit : mm)

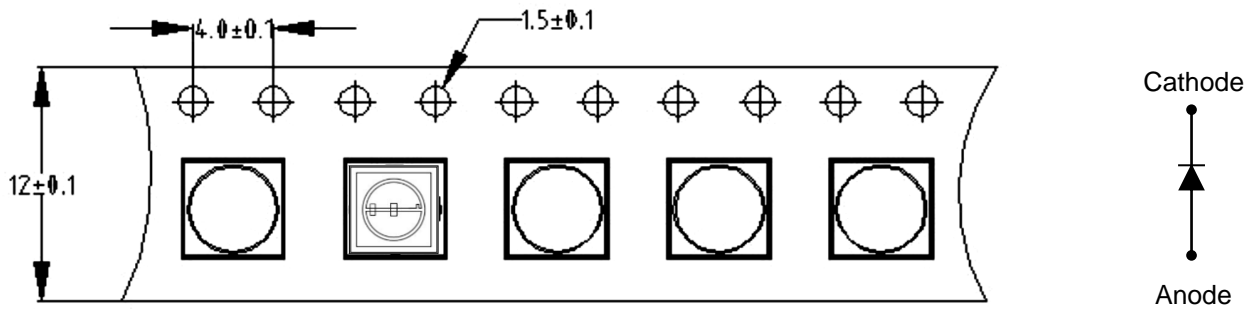

■ Carrier Reel

(Unit : mm)

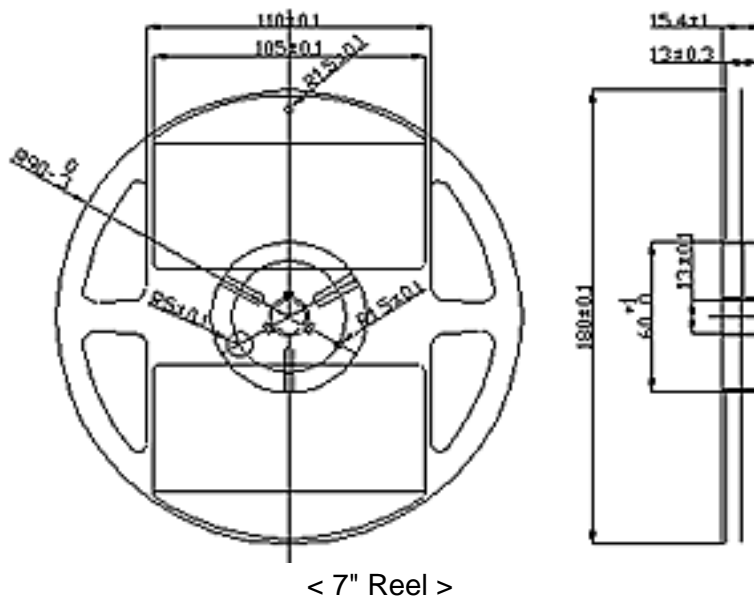

* Notes

- 1) Quantity : Taping of 1 reel will be from 100 pcs to 1,000 pcs in unit of a number in the hundreds.
- 2) Adhesion strength of cover tape is 0.1 ~ 0.7N(20gf ~60gf) when the cover tape is turned off from the carrier tape.

(2) Packing and Packaging

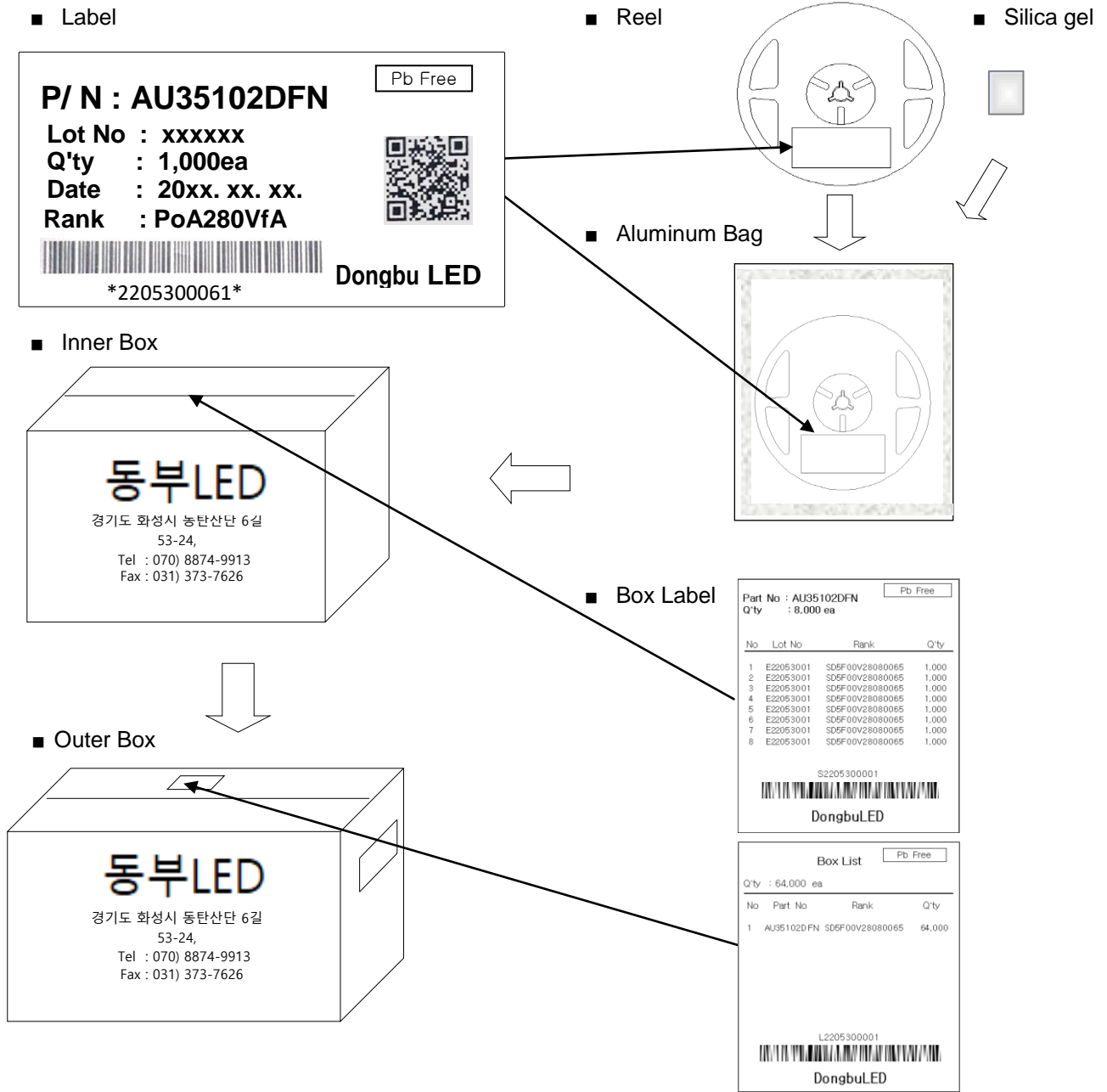

Box Type	Inner Box	Outer Box	
		Medium	Large
7" Reel Max. Packing Q'ty(pcs)	8,000	32,000	64,000

1) The carrier tape winded on the reel are placed into an ESD protected pack with a silicagel and sealed by the thermal pressure sealer. Then this sealed pack is packaged in a cardboard box.

6. Reliability Test

(1) Test Items

Test Item	Test Condition	Notes	Failure Criteria	No. of Damaged
Room Temperature Operational Life	Ta=25℃, I _F =20mA	1000 hrs	#1	0/10
High Temperature Operational Life	Ta=60℃, I _F =10mA	1000 hrs	#1	0/10
High Temperature Storage	Ta=100℃	500 hrs	#1	0/10
Low Temperature Storage	Ta=-40℃	500 hrs	#1	0/10
Thermal Shock	-45℃/15min ↔ 125℃/15min Transfer Time : 5sec	100 cycles	#2	0/10
ESD	R=1.5kΩ, C=100pF Voltage Level=2kV	3 times Negative / Positive	#1	0/10

(2) Failure Criteria

Criteria #	Parameter	Symbol	Condition	Criteria for Judgement
#1	Forward Voltage	V _F	I _F =20mA	Max. Initial Value*1.2
	Radiant Flux	Φ _e	I _F =20mA	Min. Initial Value*0.7
#2	Turn On	-	I _F =20mA	Pass / Fail

7. Precaution

(1) Static Electricity

These LEDs are highly susceptible to static electricity or surge voltage. So a wrist strap or an anti-electrostatic glove necessarily be used when handling the LEDs.

Do not use the equipment that surge voltage is came into existence.

All devices and equipment that measure or mount the LEDs must be properly grounded.

After being assembled LEDs, it should be ascertained a electrical characteristic whether that are damaged by static electricity or not.

(2) Packing

The moisture that is absorbed into the LED products may cause a badness and damage to the optical characteristics of the LEDs. Therefore the moisture barrier aluminum bag is used to keep moisture in the packing. And a silicagel is inserted into a moisture barrier aluminum bag that sealed by the thermal pressure sealer.

(3) Cleaning

This LEDs is not allowed to be used in any type of fluid such as water, oil, organic solvent, etc.

Do not clean the LEDs with an ultrasonic cleaner.

(4) Storage

In order to avoid the absorption of moisture, it is recommended to store LEDs in the moisture barrier aluminum bag is not opened.

Storage condition before opening the packing :

Temperature : below 30 °C

Humidity : 90%RH max

The LEDs should be used within a year.

Storage condition after opening the packing :

Temperature : below 30 °C

Humidity : 60%RH max

The products have to be used within one year from the date marked on label which is attached to reel or aluminium bag. After opening the packing, the LEDs should be used within 168 hours(7days). If unused LEDs remain, they should be stored in the place kept away moisture.

If the LEDs have exceeded the above storage time, it should be used after to bake using the following conditions.

Baking condition : $60\pm 5^{\circ}\text{C}$, 10 ~ 24 hours

A slight amount of sulfur, chlorine or VOC from the surrounding environment may cause discoloration of the LEDs.

(5) Heat

The LEDs are products that are generated heat. It must be considered the heat generation of the LEDs when it is designed the PCB. After considering the ambient temperature and the heat generation of LEDs, the operating current should be decided .

(6) Handling Preacutions

During The handling. Mechanical stress on the surface should be minimized as much as possible.

In general, LEDs should only be handled from the side. Grabbing the top window part could cause damaging or cracking of the window.

Glass can be damaged by force.

- Be careful not to touch the lens with tweezers or sharp tools. The lens can be shattered or fall arart.
- The product can break when it falls.
- If products were stacked after SMT, the product can be damaged.

Avoid leaving fingerprints on glass lens parts.

(7) Safety

The Products emit high intensity ultraviolet light which can make your eyes and skin harmful, so do not look directly into the UV light and wear protective.

(8) Others

If the forward or reverse voltage which exceeds the absolute maximum rating is applied to the LEDs, that will cause the damage to the LEDs. It is possible that the damaged LEDs do not light on at the current.

Be careful not to look the LEDs that the output power is strongly increased in the face. It is possible that eyesight has been getting weaker.

Light emitting part should not be exposed by physical contact. It can be the reason of material desquamation and progressive disconnection.

This LED is made for in-door use only. If the user wants the LED for out-door use, it is necessary to take some additional treatment on the product after surface mounting technology(SMT).

This specification could be changed without a notice to the customer because of the inside circumstance of the company.