

# S P E C I F I C A T I O N S

**SMD TYPE TOP VIEW WHITE LED  
HIGH CRI COLOR SOLUTION  
MODEL : AT533E□PNE**

Dongbu LED Co., Ltd.  
53-24 , Dongtansandan 6-gil , Hwaseong-si , Gyeonggi-do , Republic of Korea 18487  
Tel. : +82 - 70 - 8874 - 9943 Fax. : +82 - 31 - 373 - 7626  
[http : //www.dongbuled-s.com](http://www.dongbuled-s.com)

## 1. General Description

### (1) Features

- Package size - 5.6(L) × 3.0(W) × 0.9(T) mm
- Wide beam angle ( $2\theta_{1/2}=120\text{deg}$ )
- RoHS Compliant

### (2) Applications

- Backlighting (LCD, switches, keys, displays)
- Coupling into light guides
- Optical indicator
- General lighting

### (3) Outline Dimensions

[ Tolerance :  $\pm 0.1$ , unit : mm ]

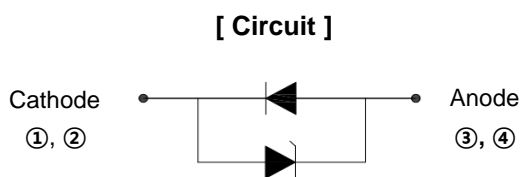
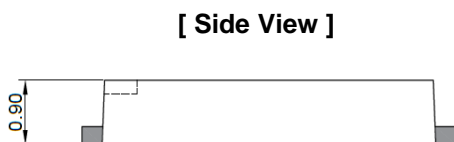
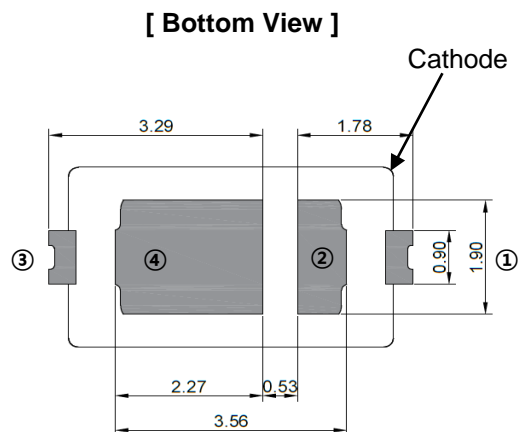
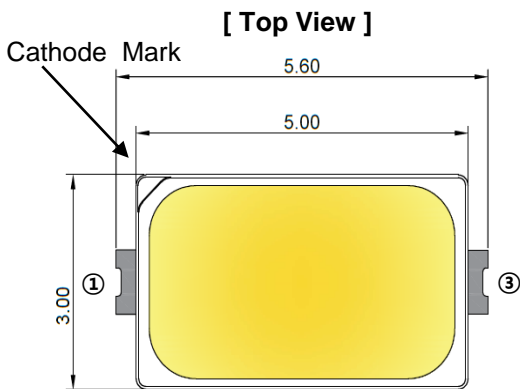

## 2. Specifications

### (1) Absolute Maximum Ratings

 (T<sub>a</sub>=25°C)

Parameter	Symbol	Absolute Maximum Rating	Unit	Remark
Power Dissipation	P <sub>D</sub>	540	mW	
Forward Current	I <sub>F</sub>	180	mA	
Operating Temperature	T <sub>OPR</sub>	-30 to +85	°C	
Storage Temperature	T <sub>STG</sub>	-40 to +100	°C	
Junction Temperature	T <sub>J</sub>	120	°C	

### (2) Initial Electrical/Optical Characteristics

 (T<sub>a</sub>=25°C)

Parameter	Symbol	Condition	Min.	Typ.	Max.	Unit
Forward Voltage	V <sub>F</sub>	I <sub>F</sub> = 65mA	2.7	-	3.0	V
Luminous Intensity	I <sub>V</sub>	I <sub>F</sub> = 65mA	11.5	-	15.5	cd
Luminous Flux	Φ <sub>V</sub>	I <sub>F</sub> = 65mA	24	-	33	lm
Reverse Voltage	V <sub>R</sub>	I <sub>R</sub> = 5mA	0.5	-	1.2	V
Color Rendering Index <sup>(1)</sup>	R <sub>a</sub>	I <sub>F</sub> = 65mA	90	-	-	-
CRI Strong Red	R <sub>9</sub>	I <sub>F</sub> = 65mA	0	-	-	R <sub>9</sub>

\* Notes : (1) Color rendering index(Ra) measurement tolerance is ± 3.

(2) Initial electrical/optical characteristics data could be changeable if the user use the product in different condition besides above data.

### (3) Characteristics Rank

#### ■ Forward Voltage Rank

 (I<sub>F</sub> = 65mA, T<sub>a</sub>=25°C)

Symbol	Rank	Min.	Max.	Unit
V <sub>F</sub>	V27	2.7	2.8	V
	V28	2.8	2.9	
	V29	2.9	3.0	

\* Notes : Forward voltage measurement tolerance is ± 0.1V.

Based on the measuring instruments of Dongbu LED

■ Luminous Flux Rank

( $I_F = 65\text{mA}$ ,  $T_a = 25^\circ\text{C}$ )

Parameter	CCT	Rank	Min.	Max.	Unit
AT533EDPNE	6500K (D00)	D1	26.0	28.0	lm
		D2	28.0	30.0	
		D3	30.0	32.0	
AT533EEPNE	5700K (E00)	D1	26.5	28.5	lm
		D2	28.5	30.5	
		D3	30.5	32.5	
AT533EFPNE	5000K (F00)	D1	27.0	29.0	lm
		D2	29.0	31.0	
		D3	31.0	33.0	
AT533EGPNE	4500K (G00)	D1	26.5	28.5	lm
		D2	28.5	30.5	
		D3	30.5	32.5	
AT533EHPNE	4000K (H00)	D1	26.0	28.0	lm
		D2	28.0	30.0	
		D3	30.0	32.0	
AT533EIPNE	3500K (I00)	D1	25.0	27.0	lm
		D2	27.0	29.0	
		D3	29.0	31.0	
AT533EJPNE	3000K (J00)	D1	24.5	26.5	lm
		D2	26.5	28.5	
		D3	28.5	30.5	
AT533EKPNE	2700K (K00)	D1	24.0	26.0	lm
		D2	26.0	28.0	
		D3	28.0	30.0	

\* Notes : Luminous flux measurement tolerance is  $\pm 7\%$ .

Based on the measuring instruments of Dongbu LED

■ Color Rank

(I<sub>F</sub> = 65mA, T<sub>a</sub>=25°C)

6500K						5700K					
Rank		Cx	Cy	Rank		Cx	Cy	Rank		Cx	Cy
<b>D00</b>		0.3068	0.3113	<b>E00</b>		0.3222	0.3243	<b>E09</b>		0.3366	0.3369
		0.3221	0.3261			0.3376	0.3616				
		0.3205	0.3481			0.3207	0.3462				
		0.3028	0.3304								
Rank	Cx	Cy	Rank	Cx	Cy	Rank	Cx	Cy	Rank	Cx	Cy
<b>D01</b>	0.3038	0.3256	<b>D09</b>	0.3123	0.3342	<b>E00</b>	0.3211	0.3407	<b>E09</b>	0.3293	0.3481
	0.3080	0.3299		0.3166	0.3384		0.3252	0.3444		0.3333	0.3518
	0.3072	0.3349		0.3160	0.3437		0.3250	0.3501		0.3334	0.3578
<b>D02</b>	0.3028	0.3304	<b>D10</b>	0.3115	0.3393	<b>E02</b>	0.3207	0.3462	<b>E10</b>	0.3292	0.3539
	0.3048	0.3209		0.3131	0.3290		0.3215	0.3353		0.3293	0.3423
	0.3089	0.3249		0.3172	0.3331		0.3254	0.3388		0.3332	0.3458
	0.3080	0.3299		0.3166	0.3384		0.3252	0.3444		0.3333	0.3518
<b>D03</b>	0.3038	0.3256	<b>D11</b>	0.3123	0.3342	<b>E03</b>	0.3211	0.3407	<b>E11</b>	0.3293	0.3481
	0.3058	0.3161		0.3138	0.3239		0.3218	0.3298		0.3294	0.3364
	0.3098	0.3200		0.3178	0.3277		0.3256	0.3331		0.3331	0.3398
	0.3089	0.3249		0.3172	0.3331		0.3254	0.3388		0.3332	0.3458
<b>D04</b>	0.3048	0.3209	<b>D12</b>	0.3131	0.3290	<b>E04</b>	0.3215	0.3353	<b>E12</b>	0.3293	0.3423
	0.3068	0.3113		0.3146	0.3187		0.3222	0.3243		0.3294	0.3306
	0.3107	0.3150		0.3184	0.3224		0.3258	0.3275		0.3330	0.3338
	0.3098	0.3200		0.3178	0.3277		0.3256	0.3331		0.3331	0.3398
<b>D05</b>	0.3058	0.3161	<b>D13</b>	0.3138	0.3239	<b>E05</b>	0.3218	0.3298	<b>E13</b>	0.3294	0.3364
	0.3080	0.3299		0.3166	0.3384		0.3252	0.3444		0.3333	0.3518
	0.3123	0.3342		0.3209	0.3426		0.3293	0.3481		0.3374	0.3554
	0.3115	0.3393		0.3205	0.3481		0.3292	0.3539		0.3376	0.3616
<b>D06</b>	0.3072	0.3349	<b>D14</b>	0.3160	0.3437	<b>E06</b>	0.3250	0.3501	<b>E14</b>	0.3334	0.3578
	0.3089	0.3249		0.3172	0.3331		0.3254	0.3388		0.3332	0.3458
	0.3131	0.3290		0.3213	0.3371		0.3293	0.3423		0.3371	0.3493
	0.3123	0.3342		0.3209	0.3426		0.3293	0.3481		0.3374	0.3554
<b>D07</b>	0.3080	0.3299	<b>D15</b>	0.3166	0.3384	<b>E07</b>	0.3252	0.3444	<b>E15</b>	0.3333	0.3518
	0.3098	0.3200		0.3178	0.3277		0.3256	0.3331		0.3331	0.3398
	0.3138	0.3239		0.3217	0.3316		0.3294	0.3364		0.3369	0.3431
	0.3131	0.3290		0.3213	0.3371		0.3293	0.3423		0.3371	0.3493
<b>D08</b>	0.3089	0.3249	<b>D16</b>	0.3172	0.3331	<b>E08</b>	0.3254	0.3388	<b>E16</b>	0.3332	0.3458
	0.3107	0.3150		0.3184	0.3224		0.3258	0.3275		0.3330	0.3338
	0.3146	0.3187		0.3221	0.3261		0.3294	0.3306		0.3366	0.3369
	0.3138	0.3239		0.3217	0.3316		0.3294	0.3364		0.3369	0.3431
	0.3098	0.3200		0.3178	0.3277		0.3256	0.3331		0.3331	0.3398

■ Color Rank

( $I_F = 65\text{mA}$ ,  $T_a = 25^\circ\text{C}$ )

5000K						4500K					
Rank		Cx	Cy	Rank		Cx	Cy	Rank		Cx	Cy
<b>F00</b>		0.3366	0.3369	<b>G00</b>		0.3512	0.3465	<b>G00</b>		0.3512	0.3465
		0.3515	0.3487			0.3670	0.3578				
		0.3551	0.3760			0.3736	0.3874				
		0.3376	0.3616			0.3548	0.3736				
Rank	Cx	Cy	Rank	Cx	Cy	Rank	Cx	Cy	Rank	Cx	Cy
<b>F01</b>	0.3374	0.3554	<b>F09</b>	0.3457	0.3622	<b>G01</b>	0.3539	0.3668	<b>G09</b>	0.3628	0.3733
	0.3415	0.3588		0.3500	0.3657		0.3584	0.3701		0.3674	0.3767
	0.3420	0.3652		0.3507	0.3724		0.3595	0.3770		0.3689	0.3839
	0.3376	0.3616		0.3463	0.3687		0.3548	0.3736		0.3641	0.3804
<b>F02</b>	0.3371	0.3493	<b>F10</b>	0.3452	0.3558	<b>G02</b>	0.3530	0.3601	<b>G10</b>	0.3616	0.3663
	0.3411	0.3525		0.3492	0.3591		0.3573	0.3632		0.3659	0.3694
	0.3415	0.3588		0.3500	0.3657		0.3584	0.3701		0.3674	0.3767
	0.3374	0.3554		0.3457	0.3622		0.3539	0.3668		0.3628	0.3733
<b>F03</b>	0.3369	0.3431	<b>F11</b>	0.3446	0.3493	<b>G03</b>	0.3520	0.3533	<b>G11</b>	0.3603	0.3592
	0.3407	0.3462		0.3485	0.3524		0.3562	0.3562		0.3645	0.3622
	0.3411	0.3525		0.3492	0.3591		0.3573	0.3632		0.3659	0.3694
	0.3371	0.3493		0.3452	0.3558		0.3530	0.3601		0.3616	0.3663
<b>F04</b>	0.3366	0.3369	<b>F12</b>	0.3440	0.3428	<b>G04</b>	0.3512	0.3465	<b>G12</b>	0.3590	0.3521
	0.3403	0.3399		0.3477	0.3458		0.3551	0.3493		0.3630	0.3550
	0.3407	0.3462		0.3485	0.3524		0.3562	0.3562		0.3645	0.3622
	0.3369	0.3431		0.3446	0.3493		0.3520	0.3533		0.3603	0.3592
<b>F05</b>	0.3415	0.3588	<b>F13</b>	0.3500	0.3657	<b>G05</b>	0.3584	0.3701	<b>G13</b>	0.3674	0.3767
	0.3457	0.3622		0.3542	0.3692		0.3628	0.3733		0.3720	0.3800
	0.3463	0.3687		0.3551	0.3760		0.3641	0.3804		0.3736	0.3874
	0.3420	0.3652		0.3507	0.3724		0.3595	0.3770		0.3689	0.3839
<b>F06</b>	0.3411	0.3525	<b>F14</b>	0.3492	0.3591	<b>G06</b>	0.3573	0.3632	<b>G14</b>	0.3659	0.3694
	0.3452	0.3558		0.3533	0.3624		0.3616	0.3663		0.3703	0.3726
	0.3457	0.3622		0.3542	0.3692		0.3628	0.3733		0.3720	0.3800
	0.3415	0.3588		0.3500	0.3657		0.3584	0.3701		0.3674	0.3767
<b>F07</b>	0.3407	0.3462	<b>F15</b>	0.3485	0.3524	<b>G07</b>	0.3562	0.3562	<b>G15</b>	0.3645	0.3622
	0.3446	0.3493		0.3524	0.3554		0.3603	0.3592		0.3687	0.3652
	0.3452	0.3558		0.3533	0.3624		0.3616	0.3663		0.3703	0.3726
	0.3411	0.3525		0.3492	0.3591		0.3573	0.3632		0.3659	0.3694
<b>F08</b>	0.3403	0.3399	<b>F16</b>	0.3477	0.3458	<b>G08</b>	0.3551	0.3493	<b>G16</b>	0.3630	0.3550
	0.3440	0.3428		0.3515	0.3487		0.3590	0.3521		0.3670	0.3578
	0.3446	0.3493		0.3524	0.3554		0.3603	0.3592		0.3687	0.3652
	0.3407	0.3462		0.3485	0.3524		0.3562	0.3562		0.3645	0.3622

■ Color Rank

( $I_F = 65\text{mA}$ ,  $T_a = 25^\circ\text{C}$ )

4000K						3500K					
Rank		Cx	Cy	Rank		Cx	Cy	Rank		Cx	Cy
<b>H00</b>		0.3670	0.3578	<b>I00</b>		0.3889	0.3690	<b>I00</b>		0.3889	0.3690
		0.3898	0.3716			0.4147	0.3814				
		0.4006	0.4044			0.4299	0.4165				
		0.3736	0.3874			0.3996	0.4015				
Rank	Cx	Cy	Rank	Cx	Cy	Rank	Cx	Cy	Rank	Cx	Cy
<b>H01</b>	0.3720	0.3800	<b>H09</b>	0.3849	0.3881	<b>I01</b>	0.3969	0.3932	<b>I09</b>	0.4114	0.4005
	0.3785	0.3841		0.3915	0.3922		0.4041	0.3969		0.4187	0.4040
	0.3804	0.3917		0.3939	0.4002		0.4071	0.4052		0.4223	0.4127
<b>H02</b>	0.3736	0.3874	<b>H10</b>	0.3871	0.3959	<b>I02</b>	0.3996	0.4015	<b>I10</b>	0.4146	0.4089
	0.3703	0.3726		0.3828	0.3803		0.3941	0.3848		0.4082	0.3922
	0.3766	0.3765		0.3890	0.3842		0.4012	0.3885		0.4151	0.3953
	0.3785	0.3841		0.3915	0.3922		0.4041	0.3969		0.4187	0.4040
<b>H03</b>	0.3720	0.3800	<b>H11</b>	0.3849	0.3881	<b>I03</b>	0.3969	0.3932	<b>I11</b>	0.4114	0.4005
	0.3687	0.3652		0.3806	0.3725		0.3915	0.3769		0.4050	0.3837
	0.3746	0.3689		0.3866	0.3762		0.3982	0.3803		0.4117	0.3868
	0.3766	0.3765		0.3890	0.3842		0.4012	0.3885		0.4151	0.3953
<b>H04</b>	0.3703	0.3726	<b>H12</b>	0.3828	0.3803	<b>I04</b>	0.3941	0.3848	<b>I12</b>	0.4082	0.3922
	0.3670	0.3578		0.3784	0.3647		0.3889	0.3690		0.4017	0.3752
	0.3727	0.3613		0.3841	0.3682		0.3951	0.3721		0.4082	0.3783
	0.3746	0.3689		0.3866	0.3762		0.3982	0.3803		0.4117	0.3868
<b>H05</b>	0.3687	0.3652	<b>H13</b>	0.3806	0.3725	<b>I05</b>	0.3915	0.3769	<b>I13</b>	0.4050	0.3837
	0.3785	0.3841		0.3915	0.3922		0.4041	0.3969		0.4187	0.4040
	0.3849	0.3881		0.3979	0.3962		0.4114	0.4005		0.4260	0.4075
	0.3871	0.3959		0.4006	0.4044		0.4146	0.4089		0.4299	0.4165
<b>H06</b>	0.3804	0.3917	<b>H14</b>	0.3939	0.4002	<b>I06</b>	0.4071	0.4052	<b>I14</b>	0.4223	0.4127
	0.3766	0.3765		0.3890	0.3842		0.4012	0.3885		0.4151	0.3953
	0.3828	0.3803		0.3952	0.3880		0.4082	0.3922		0.4221	0.3984
	0.3849	0.3881		0.3979	0.3962		0.4114	0.4005		0.4260	0.4075
<b>H07</b>	0.3785	0.3841	<b>H15</b>	0.3915	0.3922	<b>I07</b>	0.4041	0.3969	<b>I15</b>	0.4187	0.4040
	0.3746	0.3689		0.3866	0.3762		0.3982	0.3803		0.4117	0.3868
	0.3806	0.3725		0.3925	0.3798		0.4050	0.3837		0.4184	0.3899
	0.3828	0.3803		0.3952	0.3880		0.4082	0.3922		0.4221	0.3984
<b>H08</b>	0.3766	0.3765	<b>H16</b>	0.3890	0.3842	<b>I08</b>	0.4012	0.3885	<b>I16</b>	0.4151	0.3953
	0.3727	0.3613		0.3841	0.3682		0.3951	0.3721		0.4082	0.3783
	0.3784	0.3647		0.3898	0.3716		0.4017	0.3752		0.4147	0.3814
	0.3806	0.3725		0.3925	0.3798		0.4050	0.3837		0.4184	0.3899
	0.3746	0.3689		0.3866	0.3762		0.3982	0.3803		0.4117	0.3868

■ Color Rank

(I<sub>F</sub> = 65mA, T<sub>a</sub>=25°C)

3000K						2700K					
Rank		Cx	Cy	Rank		Cx	Cy	Rank		Cx	Cy
<b>J00</b>		0.4147	0.3814	<b>K00</b>		0.4373	0.3893	<b>K09</b>		0.4593	0.3944
		0.4373	0.3893			0.4813	0.4319				
		0.4562	0.4260			0.4562	0.4260				
		0.4299	0.4165								
Rank	Cx	Cy	Rank	Cx	Cy	Rank	Cx	Cy	Rank	Cx	Cy
<b>J01</b>	0.4260	0.4075	<b>J09</b>	0.4387	0.4122	<b>K01</b>	0.4513	0.4166	<b>K09</b>	0.4637	0.4196
	0.4323	0.4098		0.4450	0.4144		0.4575	0.4181		0.4697	0.4209
	0.4364	0.4189		0.4496	0.4236		0.4625	0.4275		0.4750	0.4304
<b>J02</b>	0.4299	0.4165	<b>J10</b>	0.4430	0.4212	<b>K02</b>	0.4562	0.4260	<b>K10</b>	0.4687	0.4289
	0.4221	0.3984		0.4344	0.4032		0.4465	0.4071		0.4586	0.4103
	0.4282	0.4008		0.4404	0.4052		0.4525	0.4087		0.4642	0.4114
	0.4323	0.4098		0.4450	0.4144		0.4575	0.4181		0.4697	0.4209
<b>J03</b>	0.4260	0.4075	<b>J11</b>	0.4387	0.4122	<b>K03</b>	0.4513	0.4166	<b>K11</b>	0.4637	0.4196
	0.4184	0.3899		0.4302	0.3943		0.4419	0.3982		0.4535	0.4011
	0.4243	0.3921		0.4360	0.3962		0.4477	0.3996		0.4590	0.4023
	0.4282	0.4008		0.4404	0.4052		0.4525	0.4087		0.4642	0.4114
<b>J04</b>	0.4221	0.3984	<b>J12</b>	0.4344	0.4032	<b>K04</b>	0.4465	0.4071	<b>K12</b>	0.4586	0.4103
	0.4147	0.3814		0.4260	0.3853		0.4373	0.3893		0.4483	0.3918
	0.4203	0.3834		0.4316	0.3873		0.4428	0.3906		0.4538	0.3931
	0.4243	0.3921		0.4360	0.3962		0.4477	0.3996		0.4590	0.4023
<b>J05</b>	0.4184	0.3899	<b>J13</b>	0.4302	0.3943	<b>K05</b>	0.4419	0.3982	<b>K13</b>	0.4535	0.4011
	0.4323	0.4098		0.4450	0.4144		0.4575	0.4181		0.4697	0.4209
	0.4387	0.4122		0.4513	0.4166		0.4637	0.4196		0.4756	0.4223
	0.4430	0.4212		0.4562	0.4260		0.4687	0.4289		0.4813	0.4319
<b>J06</b>	0.4364	0.4189	<b>J14</b>	0.4496	0.4236	<b>K06</b>	0.4625	0.4275	<b>K14</b>	0.4750	0.4304
	0.4282	0.4008		0.4404	0.4052		0.4525	0.4087		0.4642	0.4114
	0.4344	0.4032		0.4465	0.4071		0.4586	0.4103		0.4700	0.4126
	0.4387	0.4122		0.4513	0.4166		0.4637	0.4196		0.4756	0.4223
<b>J07</b>	0.4323	0.4098	<b>J15</b>	0.4450	0.4144	<b>K07</b>	0.4575	0.4181	<b>K15</b>	0.4697	0.4209
	0.4243	0.3921		0.4360	0.3962		0.4477	0.3996		0.4590	0.4023
	0.4302	0.3943		0.4419	0.3982		0.4535	0.4011		0.4646	0.4035
	0.4344	0.4032		0.4465	0.4071		0.4586	0.4103		0.4700	0.4126
<b>J08</b>	0.4282	0.4008	<b>J16</b>	0.4404	0.4052	<b>K08</b>	0.4525	0.4087	<b>K16</b>	0.4642	0.4114
	0.4203	0.3834		0.4316	0.3873		0.4428	0.3906		0.4538	0.3931
	0.4260	0.3853		0.4373	0.3893		0.4483	0.3918		0.4593	0.3944
	0.4302	0.3943		0.4419	0.3982		0.4535	0.4011		0.4646	0.4035
	0.4243	0.3921		0.4360	0.3962		0.4477	0.3996		0.4590	0.4023

\* Notes : (1) The color coordinates measurement tolerance is ± 0.01.

Based on the measuring instruments of Dongbu LED

(2) The chromaticity coordinates refer to CIE 1931 chromaticity diagram.



■ CIE Chromaticity Diagram

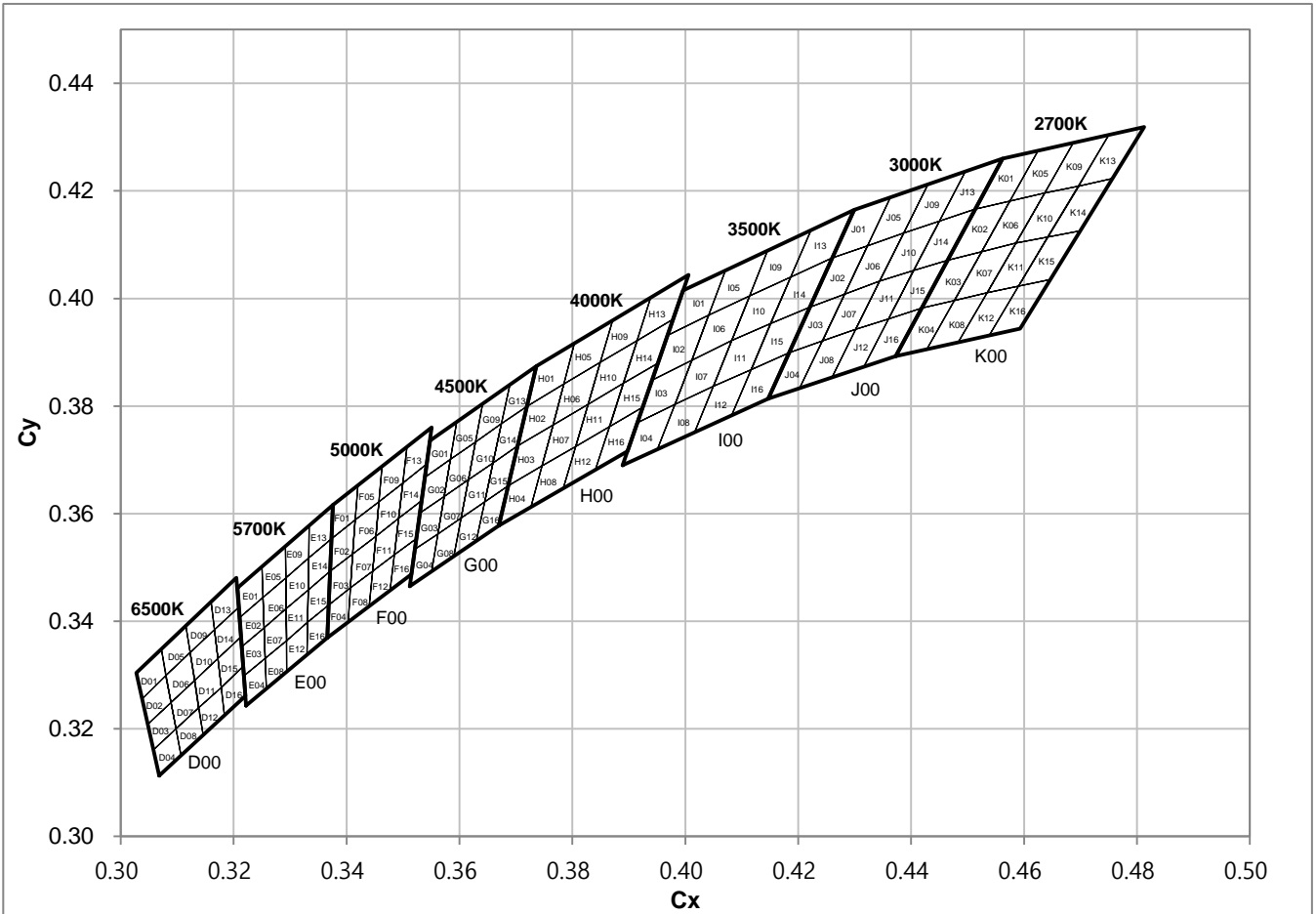

Ex ) F00 (5000K) 16 Rank Bin

Ex ) F00 (5000K) 5 Rank Bin

Ex ) F00 (5000K) 1 Rank Bin

F01	F05	F09	F13
F02	F06	F10	F14
F03	F07	F11	F15
F04	F08	F12	F16

<b>F51</b>	F05	F09	<b>F52</b>
F02	<b>F06</b>	<b>F10</b>	F14
F03	<b>F07</b>	<b>F11</b>	F15
<b>F53</b>	F08	F12	<b>F54</b>

<b>F01</b>	<b>F05</b>	<b>F09</b>	<b>F13</b>
<b>F02</b>	<b>F06</b>	<b>F10</b>	<b>F14</b>
<b>F03</b>	<b>F07</b>	<b>F11</b>	<b>F15</b>
<b>F04</b>	<b>F08</b>	<b>F12</b>	<b>F16</b>

**3. Rank Code**

The rank inscription is composed of the follow method.

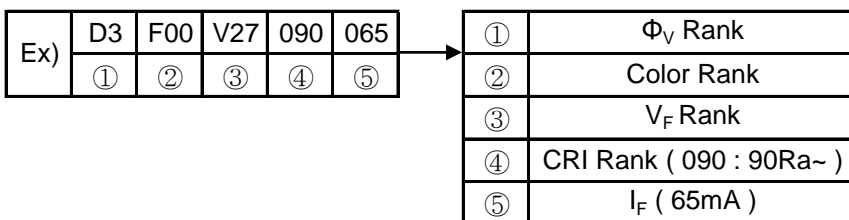

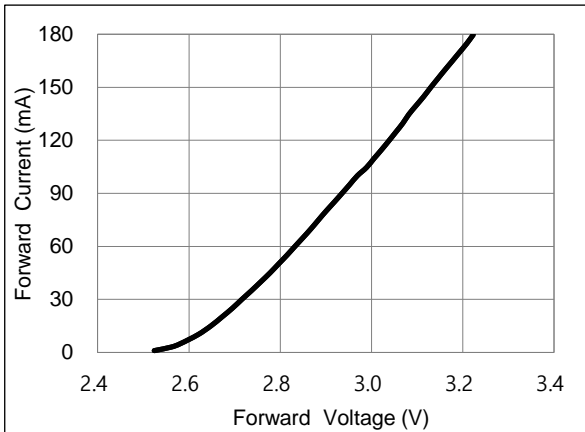
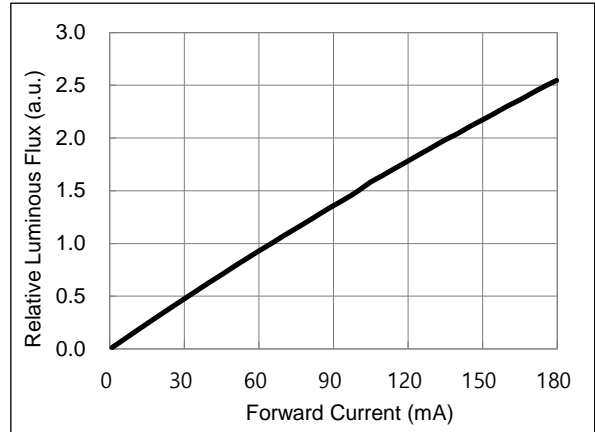
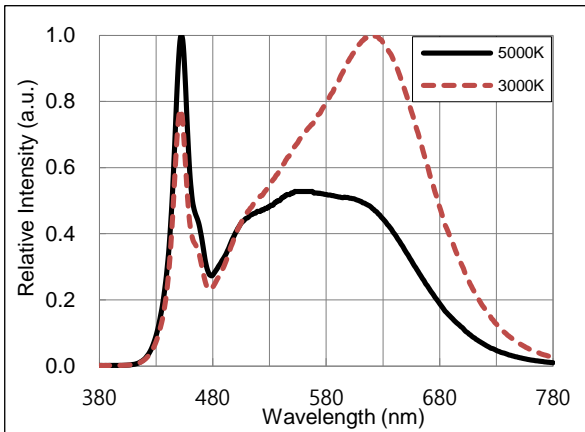
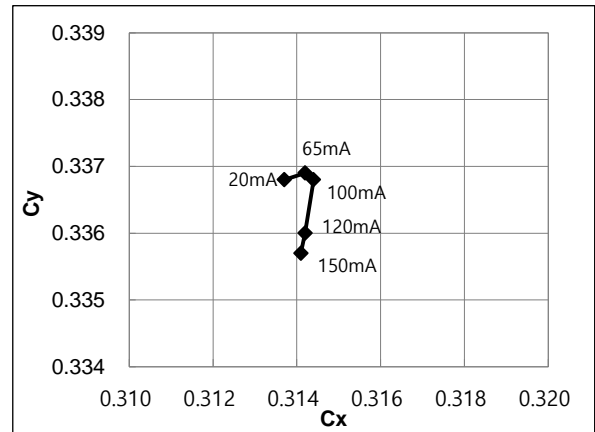
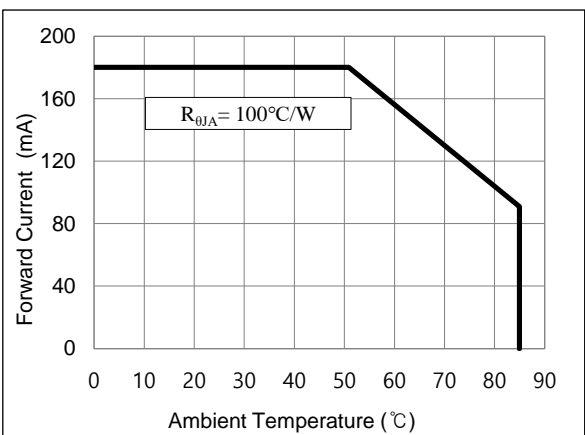
**4. Characteristics Diagrams**

 Forward Voltage vs Forward Current,  $T_a=25^\circ\text{C}$ 

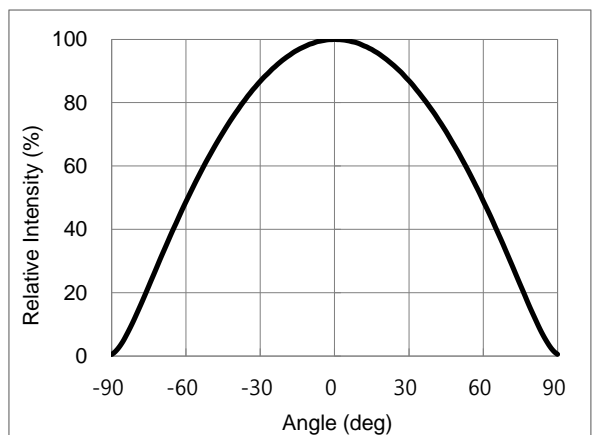
 Forward Current vs Relative Luminous Flux,  $T_a=25^\circ\text{C}$ 

 Spectrum,  $T_a=25^\circ\text{C}$ ,  $I_F=65\text{mA}$ 

 Forward Current vs Chromaticity Coordinate,  $T_a=25^\circ\text{C}$ 

Derating Curve

 Beam Angle,  $T_a=25^\circ\text{C}$ ,  $I_F=65\text{mA}$ 

\* Note : The graph of characteristics is the sampling data for the reference.

## 5. Soldering Conditions

### (1) Recommended Soldering Conditions

Conditions	Reflow Soldering		Hand Soldering	
	Lead Solder	Lead-Free Solder		
Pre-Heating	120 ~ 150 °C	180 ~ 200 °C	Temperature Soldering time	300 °C Max. 3 sec. Max. (one time only)
Pre-Heat Time	120sec. Max.	120sec. Max.		
Peak Temperature	240 °C Max.	260 °C Max.		
Soldering Time	5sec. Max.	5sec. Max.		

\* After reflow soldering, rapid cooling should be avoid.

### (2) Recommended Reflow Soldering Profile

#### ■ Lead Solder

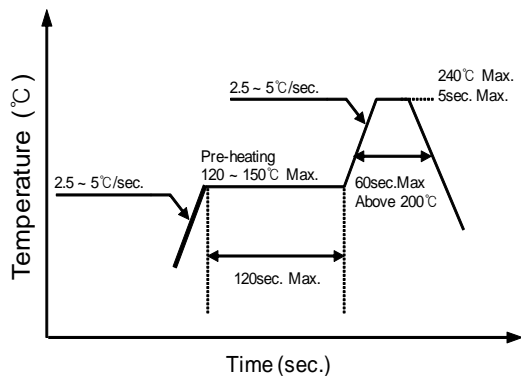

#### ■ Lead Free Solder

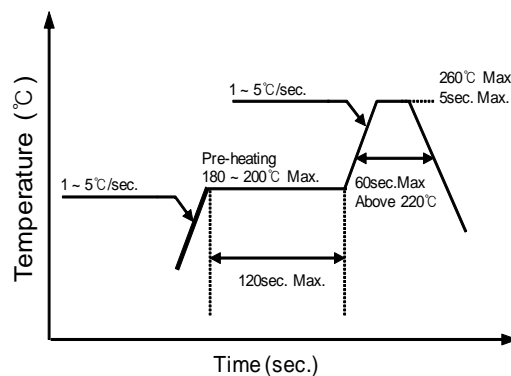

### (3) Recommended Soldering Pad Pattern

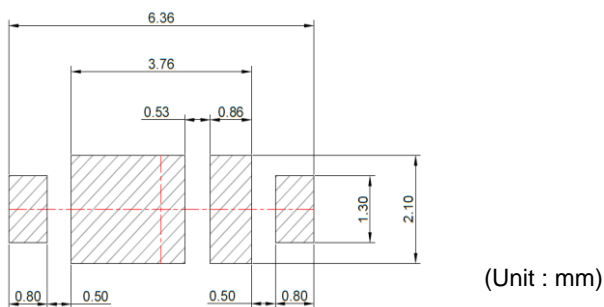

### (4) Soldering Cautions

- Reflow soldering should not be done more than two times.
- When soldering, do not put stress on the LEDs during heating.
- After soldering, do not wrap the circuit board.
- The LEDs can be soldered on place using the reflow soldering method.
- Occasionally there is a brightness decrease cause by the influence of heat or ambient atmosphere during air reflow. It is recommend that the user use the nitrogen reflow method.
- After complete soldering, the product should be handled after cooling. (required to be handled under 60 °C)

## 6. Packing

### (1) Carrier Tape & Carrier Reel Dimensions

#### Carrier Tape

(Unit : mm)

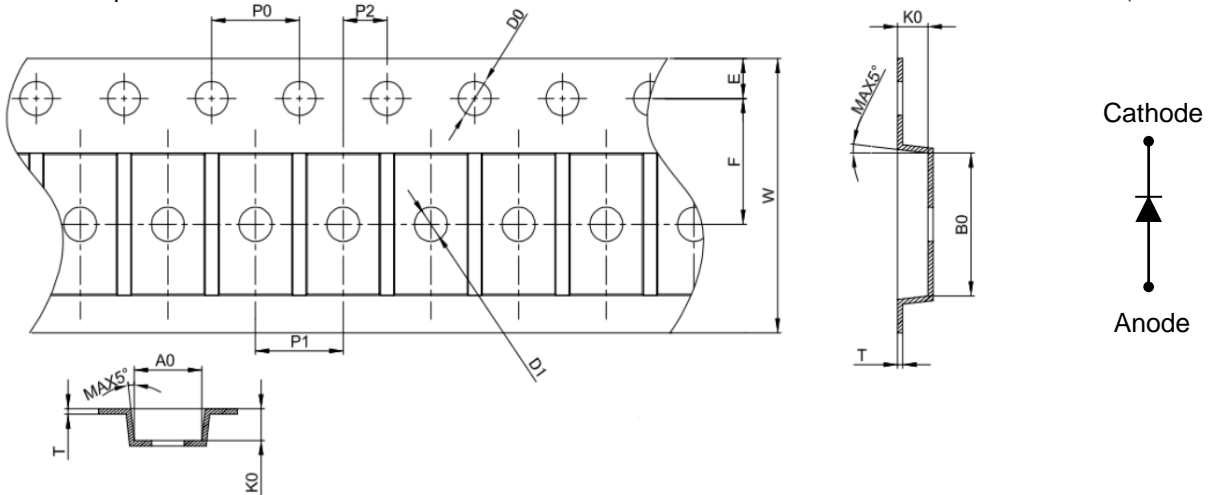

Symbol	A0	B0	K0	P0	P1	P2
Spec	3.22±0.10	5.82±0.10	1.30±0.10	4.00±0.10	.00±0.10	2.00±0.05
Symbol	T	E	F	D0	D1	W
Spec	0.25±0.05	1.75±0.10	5.50±0.10	1.50±0.10	1.50 Min	12.0±0.3

#### Carrier Reel

(Unit : mm)

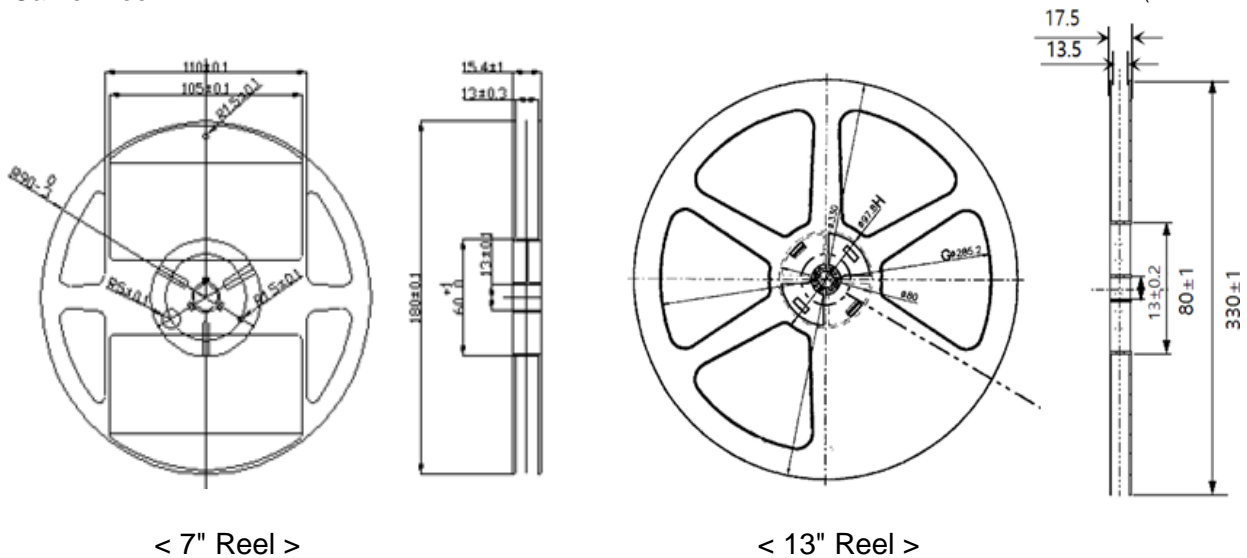

< 7" Reel >

< 13" Reel >

#### \* Notes

- Quantity : Taping of 7" reel will be from 1,000 pcs to 3,000 pcs in unit of a number in the thousands.  
Taping of 13" reel will be from 5,000 pcs to 10,000 pcs in unit of a number in the thousands.
- Adhesion strength of cover tape is 0.1 ~ 0.7N(20gf ~60gf) when the cover tape is turned off from the carrier tape.

## (2) Packing and Packaging

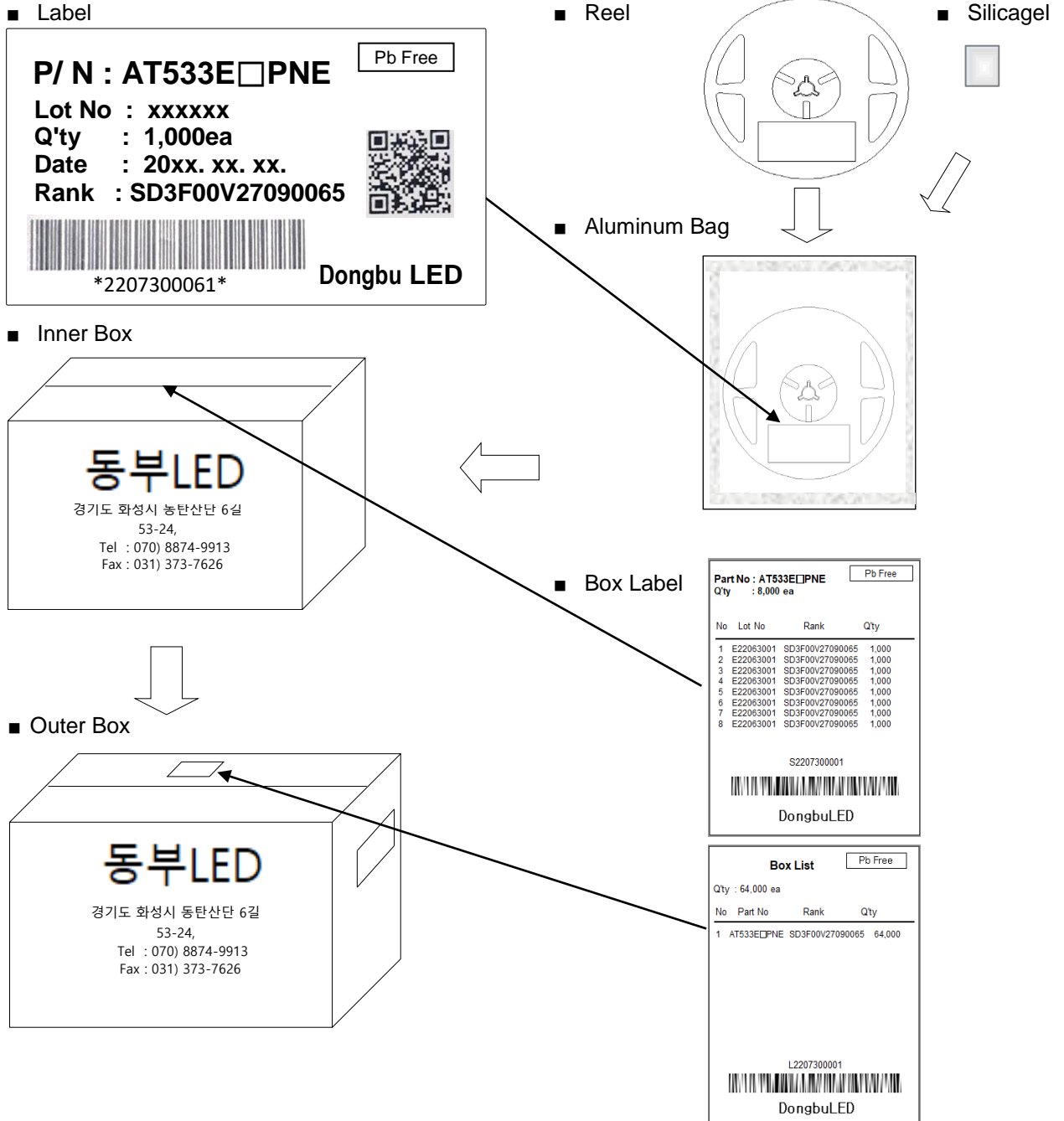

Box Type	Inner Box	Outer Box	
		Medium	Large
7" Reel Max. Packing Q'ty(pcs)	8,000	32,000	64,000
13" Reel Max. Packing Q'ty(pcs)	10,000	60,000	

1) The carrier tape winded on the reel are placed into an ESD protected pack with a silicagel and sealed by the thermal pressure sealer. Then this sealed pack is packaged in a cardboard box.

## 7. Precaution

### (1) Static Electricity

These LEDs are highly susceptible to static electricity or surge voltage. So a wrist strap or an anti-electrostatic glove necessarily be used when handling the LEDs.

Do not use the equipment that surge voltage is came into existence.

All devices and equipment that measure or mount the LEDs must be properly grounded.

After being assembled LEDs, it should be ascertained a electrical characteristic whether that are damaged by static electricity or not.

### (2) Packing

The moisture that is absorbed into the LED products may cause a badness and damage to the optical characteristics of the LEDs. Therefore the moisture barrier aluminum bag is used to keep moisture in the packing. And a silicagel is inserted into a moisture barrier aluminum bag that sealed by the thermal pressure sealer.

### (3) Cleaning

Ethanol can be used for LED cleaning. The maximum exposure time with ethanol is 1 minute for cleaning.

Do not use ultrasonic for cleaning the LEDs or other solvents, If ultrasonic cleaning is absolutely necessary, a pre-test should be done before cleaning to see if the LED is damaged.

### (4) Storage

In order to avoid the absorption of moisture, it is recommended to store LEDs in the moisture barrier aluminum bag is not opened.

Storage condition before opening the packing :

Temperature : below 30℃

Humidity : 90%RH max

The LEDs should be used within a year.

Storage condition after opening the packing :

Temperature : below 30℃

Humidity : 60%RH max

The products have to be used within one year from the date marked on label which is attached to reel or aluminium bag. After opening the packing, the LEDs should be used within 168 hours(7days). If unused LEDs remain, they should be stored in the place kept away moisture.

If the LEDs have exceeded the above storage time, it should be used after to bake using the following conditions.

Baking condition : 60±5℃, 10 ~ 24 hours

A slight amount of sulfur, chlorine or VOC from the surrounding environment may cause discoloration of the LEDs.

**(5) Pick and Place**

It should be avoided to rub or scratch the surface of resin by any hard material. It is possible that the LEDs are damaged to the optical characteristics.

**(6) Heat**

The LEDs are products that are generated heat. It must be considered the heat generation of the LEDs when it is designed the PCB. After considering the ambient temperature and the heat generation of LEDs, the operating current should be decided .

**(7) Others**

If the forward or reverse voltage which exceeds the absolute maximum rating is applied to the LEDs, that will cause the damage to the LEDs. It is possible that the damaged LEDs do not light on at the current.

Be careful not to look the LEDs that the output power is strongly increased in the face. It is possible that eyesight has been getting weaker.

Light emitting part should not be exposed by physical contact. It can be the reason of material desquamation and progressive disconnection.

This LED is made for in-door use only. If the user wants the LED for out-door use, it is necessary to take some additional treatment on the product after surface mounting technology(SMT).

This specification could be changed without a notice to the customer because of the inside circumstance of the company.