

S P E C I F I C A T I O N S

SMD TYPE TOP VIEW WHITE LED MODEL : AT285L□PDA

Dongbu LED Co., Ltd.
53-24 , Dongtansandan 6-gil , Hwaseong-si , Gyeonggi-do , Republic of Korea 18487
Tel. : +82 - 70 - 8874 - 9943 Fax. : +82 - 31 - 373 - 7626
[http : //www.dongbuled-s.com](http://www.dongbuled-s.com)

1. General Description

(1) Features

- Package size - 2.8(L) × 3.5(W) × 0.65(T) mm
- Wide beam angle ($2\theta_{1/2}=120\text{deg}$)
- RoHS Compliant

(2) Applications

- Coupling into light guides
- Optical indicator
- Interior automotive lighting

(3) Outline Dimensions

[Tolerance : ± 0.1 , unit : mm]

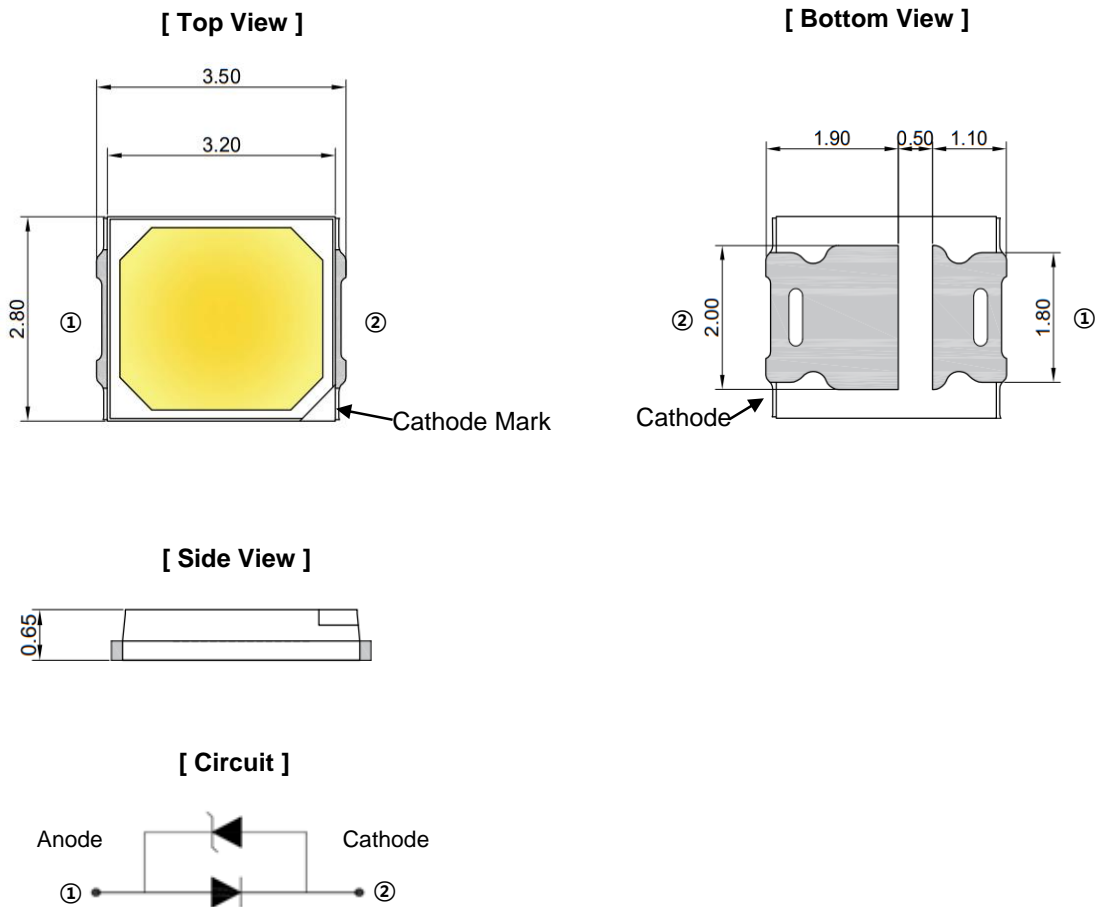

2. Specifications

(1) Absolute Maximum Ratings

					(T _a =25℃)
Parameter	Symbol	Absolute Maximum Rating	Unit	Remark	
Power Dissipation	P _D	480	mW		
Forward Current	I _F	150	mA		
Operating Temperature	T _{OPR}	-30 to +85	℃		
Storage Temperature	T _{STG}	-40 to +100	℃		
Junction Temperature	T _J	120	℃		

(2) Initial Electrical/Optical Characteristics

							(T _a =25℃)
Parameter	Symbol	Condition	Min.	Typ.	Max.	Unit	
Forward Voltage	V _F	I _F = 65mA	2.7	-	3.2	V	
Luminous Intensity	I _V	I _F = 65mA	11.5	-	15.5	cd	
Luminous Flux	Φ _V	I _F = 65mA	25.0	-	35.0	lm	
Reverse Voltage	V _R	I _R = 5mA	0.5	-	1.2	V	
Color Rendering Index ⁽¹⁾	Ra	I _F = 65mA	80	-	-	-	

* Notes : (1) Color rendering index(Ra) measurement tolerance is ± 3.

(2) Initial electrical/optical characteristics data could be changeable if the user use the product in different condition besides above data.

(3) Characteristics Rank

■ Forward Voltage Rank

					(I _F = 65mA, T _a =25℃)
Symbol	Rank	Min.	Max.	Unit	
V _F	V27	2.7	2.8	V	
	V28	2.8	2.9		
	V29	2.9	3.0		
	V30	3.0	3.1		
	V31	3.1	3.2		

* Notes : Forward voltage measurement tolerance is ± 0.1V.

Based on the measuring instruments of Dongbu LED

■ Luminous Flux Rank

 (I_F = 65mA, T_a=25℃)

Parameter	CCT	Rank	Min.	Max.	Unit
AT285LDPDA	6500K (D00)	D2P	27.0	29.0	lm
		D2	28.0	30.0	
		D3	30.0	32.0	
		D4	32.0	34.0	
AT285LEPDA	5700K (E00)	D2P	27.5	29.5	lm
		D2	28.5	30.5	
		D3	30.5	32.5	
		D4	32.5	34.5	
AT285LFPDA	5000K (F00)	D2P	28.0	30.0	lm
		D2	29.0	31.0	
		D3	31.0	33.0	
		D4	33.0	35.0	
AT285LGPDA	4500K (G00)	D2P	28.0	30.0	lm
		D2	29.0	31.0	
		D3	31.0	33.0	
		D4	33.0	35.0	
AT285LHPDA	4000K (H00)	D2P	27.0	29.0	lm
		D2	28.0	30.0	
		D3	30.0	32.0	
		D4	32.0	34.0	
AT285LIPDA	3500K (I00)	D2P	26.0	28.0	lm
		D2	27.0	29.0	
		D3	29.0	31.0	
		D4	31.0	33.0	
AT285LJPDA	3000K (J00)	D2P	25.5	27.5	lm
		D2	26.5	28.5	
		D3	28.5	30.5	
		D4	30.5	32.5	
AT285LKPDA	2700K (K00)	D2P	25.0	27.0	lm
		D2	26.0	28.0	
		D3	28.0	30.0	
		D4	30.0	32.0	

* Notes : Luminous flux measurement tolerance is ± 7%.

Based on the measuring instruments of Dongbu LED

■ Color Rank

 (I_F = 65mA, T_a=25℃)

6500K						5700K					
Rank		Cx	Cy	Rank		Cx	Cy	Rank		Cx	Cy
D00		0.3068	0.3113	E00		0.3222	0.3243	E09		0.3366	0.3369
		0.3221	0.3261			0.3376	0.3616				
		0.3205	0.3481			0.3207	0.3462				
		0.3028	0.3304								
Rank	Cx	Cy	Rank	Cx	Cy	Rank	Cx	Cy	Rank	Cx	Cy
D01	0.3038	0.3256	D09	0.3123	0.3342	E00	0.3211	0.3407	E09	0.3293	0.3481
	0.3080	0.3299		0.3166	0.3384		0.3252	0.3444		0.3333	0.3518
	0.3072	0.3349		0.3160	0.3437		0.3250	0.3501		0.3334	0.3578
D02	0.3028	0.3304	D10	0.3115	0.3393	E02	0.3207	0.3462	E10	0.3292	0.3539
	0.3048	0.3209		0.3131	0.3290		0.3215	0.3353		0.3293	0.3423
	0.3089	0.3249		0.3172	0.3331		0.3254	0.3388		0.3332	0.3458
D03	0.3080	0.3299	D11	0.3166	0.3384	E03	0.3252	0.3444	E11	0.3333	0.3518
	0.3038	0.3256		0.3123	0.3342		0.3211	0.3407		0.3293	0.3481
	0.3058	0.3161		0.3138	0.3239		0.3218	0.3298		0.3294	0.3364
D04	0.3098	0.3200	D12	0.3178	0.3277	E04	0.3256	0.3331	E12	0.3331	0.3398
	0.3089	0.3249		0.3172	0.3331		0.3254	0.3388		0.3332	0.3458
	0.3048	0.3209		0.3131	0.3290		0.3215	0.3353		0.3293	0.3423
D05	0.3068	0.3113	D13	0.3146	0.3187	E05	0.3222	0.3243	E13	0.3294	0.3306
	0.3107	0.3150		0.3184	0.3224		0.3258	0.3275		0.3330	0.3338
	0.3098	0.3200		0.3178	0.3277		0.3256	0.3331		0.3331	0.3398
D06	0.3058	0.3161	D14	0.3138	0.3239	E06	0.3218	0.3298	E14	0.3294	0.3364
	0.3080	0.3299		0.3166	0.3384		0.3252	0.3444		0.3333	0.3518
	0.3123	0.3342		0.3209	0.3426		0.3293	0.3481		0.3332	0.3458
D07	0.3115	0.3393	D15	0.3205	0.3481	E07	0.3292	0.3539	E15	0.3374	0.3554
	0.3072	0.3349		0.3160	0.3437		0.3250	0.3501		0.3334	0.3578
	0.3089	0.3249		0.3172	0.3331		0.3254	0.3388		0.3332	0.3458
D08	0.3131	0.3290	D16	0.3213	0.3371	E08	0.3293	0.3423	E16	0.3371	0.3493
	0.3123	0.3342		0.3209	0.3426		0.3293	0.3481		0.3374	0.3554
	0.3080	0.3299		0.3166	0.3384		0.3252	0.3444		0.3333	0.3518
	0.3098	0.3200		0.3178	0.3277		0.3256	0.3331		0.3331	0.3398
	0.3138	0.3239		0.3217	0.3316		0.3294	0.3364		0.3369	0.3431
	0.3131	0.3290		0.3213	0.3371		0.3293	0.3423		0.3371	0.3493
	0.3089	0.3249		0.3172	0.3331		0.3254	0.3388		0.3332	0.3458
	0.3107	0.3150		0.3184	0.3224		0.3258	0.3275		0.3330	0.3338
	0.3146	0.3187		0.3221	0.3261		0.3294	0.3306		0.3366	0.3369
	0.3138	0.3239		0.3217	0.3316		0.3294	0.3364		0.3369	0.3431
	0.3098	0.3200		0.3178	0.3277		0.3256	0.3331		0.3331	0.3398

■ Color Rank

 (I_F = 65mA, T_a=25℃)

5000K						4500K					
Rank		Cx	Cy	Rank		Cx	Cy	Rank		Cx	Cy
F00		0.3366	0.3369	G00		0.3512	0.3465	G00		0.3512	0.3465
		0.3515	0.3487			0.3670	0.3578				
		0.3551	0.3760			0.3736	0.3874				
		0.3376	0.3616			0.3548	0.3736				
Rank	Cx	Cy	Rank	Cx	Cy	Rank	Cx	Cy	Rank	Cx	Cy
F01	0.3374	0.3554	F09	0.3457	0.3622	G01	0.3539	0.3668	G09	0.3628	0.3733
	0.3415	0.3588		0.3500	0.3657		0.3584	0.3701		0.3674	0.3767
	0.3420	0.3652		0.3507	0.3724		0.3595	0.3770		0.3689	0.3839
	0.3376	0.3616		0.3463	0.3687		0.3548	0.3736		0.3641	0.3804
F02	0.3371	0.3493	F10	0.3452	0.3558	G02	0.3530	0.3601	G10	0.3616	0.3663
	0.3411	0.3525		0.3492	0.3591		0.3573	0.3632		0.3659	0.3694
	0.3415	0.3588		0.3500	0.3657		0.3584	0.3701		0.3674	0.3767
	0.3374	0.3554		0.3457	0.3622		0.3539	0.3668		0.3628	0.3733
F03	0.3369	0.3431	F11	0.3446	0.3493	G03	0.3520	0.3533	G11	0.3603	0.3592
	0.3407	0.3462		0.3485	0.3524		0.3562	0.3562		0.3645	0.3622
	0.3411	0.3525		0.3492	0.3591		0.3573	0.3632		0.3659	0.3694
	0.3371	0.3493		0.3452	0.3558		0.3530	0.3601		0.3616	0.3663
F04	0.3366	0.3369	F12	0.3440	0.3428	G04	0.3512	0.3465	G12	0.3590	0.3521
	0.3403	0.3399		0.3477	0.3458		0.3551	0.3493		0.3630	0.3550
	0.3407	0.3462		0.3485	0.3524		0.3562	0.3562		0.3645	0.3622
	0.3369	0.3431		0.3446	0.3493		0.3520	0.3533		0.3603	0.3592
F05	0.3415	0.3588	F13	0.3500	0.3657	G05	0.3584	0.3701	G13	0.3674	0.3767
	0.3457	0.3622		0.3542	0.3692		0.3628	0.3733		0.3720	0.3800
	0.3463	0.3687		0.3551	0.3760		0.3641	0.3804		0.3736	0.3874
	0.3420	0.3652		0.3507	0.3724		0.3595	0.3770		0.3689	0.3839
F06	0.3411	0.3525	F14	0.3492	0.3591	G06	0.3573	0.3632	G14	0.3659	0.3694
	0.3452	0.3558		0.3533	0.3624		0.3616	0.3663		0.3703	0.3726
	0.3457	0.3622		0.3542	0.3692		0.3628	0.3733		0.3720	0.3800
	0.3415	0.3588		0.3500	0.3657		0.3584	0.3701		0.3674	0.3767
F07	0.3407	0.3462	F15	0.3485	0.3524	G07	0.3562	0.3562	G15	0.3645	0.3622
	0.3446	0.3493		0.3524	0.3554		0.3603	0.3592		0.3687	0.3652
	0.3452	0.3558		0.3533	0.3624		0.3616	0.3663		0.3703	0.3726
	0.3411	0.3525		0.3492	0.3591		0.3573	0.3632		0.3659	0.3694
F08	0.3403	0.3399	F16	0.3477	0.3458	G08	0.3551	0.3493	G16	0.3630	0.3550
	0.3440	0.3428		0.3515	0.3487		0.3590	0.3521		0.3670	0.3578
	0.3446	0.3493		0.3524	0.3554		0.3603	0.3592		0.3687	0.3652
	0.3407	0.3462		0.3485	0.3524		0.3562	0.3562		0.3645	0.3622

■ Color Rank

 (I_F = 65mA, T_a=25℃)

4000K						3500K					
Rank		Cx	Cy	Rank		Cx	Cy	Rank		Cx	Cy
H00		0.3670	0.3578	I00		0.3889	0.3690	I00		0.3889	0.3690
		0.3898	0.3716			0.4147	0.3814				
		0.4006	0.4044			0.4299	0.4165				
		0.3736	0.3874			0.3996	0.4015				
Rank	Cx	Cy	Rank	Cx	Cy	Rank	Cx	Cy	Rank	Cx	Cy
H01	0.3720	0.3800	H09	0.3849	0.3881	I01	0.3969	0.3932	I09	0.4114	0.4005
	0.3785	0.3841		0.3915	0.3922		0.4041	0.3969		0.4187	0.4040
	0.3804	0.3917		0.3939	0.4002		0.4071	0.4052		0.4223	0.4127
H02	0.3736	0.3874	H10	0.3871	0.3959	I02	0.3996	0.4015	I10	0.4146	0.4089
	0.3703	0.3726		0.3828	0.3803		0.3941	0.3848		0.4082	0.3922
	0.3766	0.3765		0.3890	0.3842		0.4012	0.3885		0.4151	0.3953
H03	0.3785	0.3841	H11	0.3915	0.3922	I03	0.4041	0.3969	I11	0.4187	0.4040
	0.3720	0.3800		0.3849	0.3881		0.3969	0.3932		0.4114	0.4005
	0.3687	0.3652		0.3806	0.3725		0.3915	0.3769		0.4050	0.3837
H04	0.3746	0.3689	H12	0.3866	0.3762	I04	0.3982	0.3803	I12	0.4117	0.3868
	0.3766	0.3765		0.3890	0.3842		0.4012	0.3885		0.4151	0.3953
	0.3703	0.3726		0.3828	0.3803		0.3941	0.3848		0.4082	0.3922
H05	0.3670	0.3578	H13	0.3784	0.3647	I05	0.3889	0.3690	I13	0.4017	0.3752
	0.3727	0.3613		0.3841	0.3682		0.3951	0.3721		0.4082	0.3783
	0.3746	0.3689		0.3866	0.3762		0.3982	0.3803		0.4117	0.3868
H06	0.3687	0.3652	H14	0.3806	0.3725	I06	0.3915	0.3769	I14	0.4050	0.3837
	0.3785	0.3841		0.3915	0.3922		0.4041	0.3969		0.4187	0.4040
	0.3849	0.3881		0.3979	0.3962		0.4114	0.4005		0.4260	0.4075
H07	0.3871	0.3959	H15	0.4006	0.4044	I07	0.4146	0.4089	I15	0.4299	0.4165
	0.3804	0.3917		0.3939	0.4002		0.4071	0.4052		0.4223	0.4127
	0.3766	0.3765		0.3890	0.3842		0.4012	0.3885		0.4151	0.3953
H08	0.3828	0.3803	H16	0.3952	0.3880	I08	0.4082	0.3922	I16	0.4221	0.3984
	0.3849	0.3881		0.3979	0.3962		0.4114	0.4005		0.4260	0.4075
	0.3785	0.3841		0.3915	0.3922		0.4041	0.3969		0.4187	0.4040
H08	0.3746	0.3689	H16	0.3866	0.3762	I08	0.3982	0.3803	I16	0.4117	0.3868
	0.3806	0.3725		0.3925	0.3798		0.4050	0.3837		0.4184	0.3899
	0.3727	0.3613		0.3841	0.3682		0.3951	0.3721		0.4082	0.3783
H08	0.3784	0.3647	H16	0.3898	0.3716	I08	0.4017	0.3752	I16	0.4147	0.3814
	0.3806	0.3725		0.3925	0.3798		0.4050	0.3837		0.4184	0.3899
	0.3746	0.3689		0.3866	0.3762		0.3982	0.3803		0.4117	0.3868

■ Color Rank

 (I_F = 65mA, T_a=25℃)

3000K						2700K					
Rank		Cx	Cy	Rank		Cx	Cy	Rank		Cx	Cy
J00		0.4147	0.3814	K00		0.4373	0.3893	K09		0.4593	0.3944
		0.4373	0.3893			0.4813	0.4319				
		0.4562	0.4260			0.4562	0.4260				
		0.4299	0.4165								
Rank	Cx	Cy	Rank	Cx	Cy	Rank	Cx	Cy	Rank	Cx	Cy
J01	0.4260	0.4075	J09	0.4387	0.4122	K01	0.4513	0.4166	K10	0.4637	0.4196
	0.4323	0.4098		0.4450	0.4144		0.4575	0.4181		0.4697	0.4209
	0.4364	0.4189		0.4496	0.4236		0.4625	0.4275		0.4750	0.4304
	0.4299	0.4165		0.4430	0.4212		0.4562	0.4260		0.4687	0.4289
J02	0.4221	0.3984	J10	0.4344	0.4032	K02	0.4465	0.4071	K11	0.4586	0.4103
	0.4282	0.4008		0.4404	0.4052		0.4525	0.4087		0.4642	0.4114
	0.4323	0.4098		0.4450	0.4144		0.4575	0.4181		0.4697	0.4209
	0.4260	0.4075		0.4387	0.4122		0.4513	0.4166		0.4637	0.4196
J03	0.4184	0.3899	J11	0.4302	0.3943	K03	0.4419	0.3982	K12	0.4535	0.4011
	0.4243	0.3921		0.4360	0.3962		0.4477	0.3996		0.4590	0.4023
	0.4282	0.4008		0.4404	0.4052		0.4525	0.4087		0.4642	0.4114
	0.4221	0.3984		0.4344	0.4032		0.4465	0.4071		0.4586	0.4103
J04	0.4147	0.3814	J12	0.4260	0.3853	K04	0.4373	0.3893	K13	0.4483	0.3918
	0.4203	0.3834		0.4316	0.3873		0.4428	0.3906		0.4538	0.3931
	0.4243	0.3921		0.4360	0.3962		0.4477	0.3996		0.4590	0.4023
	0.4184	0.3899		0.4302	0.3943		0.4419	0.3982		0.4535	0.4011
J05	0.4323	0.4098	J13	0.4450	0.4144	K05	0.4575	0.4181	K14	0.4697	0.4209
	0.4387	0.4122		0.4513	0.4166		0.4637	0.4196		0.4756	0.4223
	0.4430	0.4212		0.4562	0.4260		0.4687	0.4289		0.4813	0.4319
	0.4364	0.4189		0.4496	0.4236		0.4625	0.4275		0.4750	0.4304
J06	0.4282	0.4008	J14	0.4404	0.4052	K06	0.4525	0.4087	K15	0.4642	0.4114
	0.4344	0.4032		0.4465	0.4071		0.4586	0.4103		0.4700	0.4126
	0.4387	0.4122		0.4513	0.4166		0.4637	0.4196		0.4756	0.4223
	0.4323	0.4098		0.4450	0.4144		0.4575	0.4181		0.4697	0.4209
J07	0.4243	0.3921	J15	0.4360	0.3962	K07	0.4477	0.3996	K16	0.4590	0.4023
	0.4302	0.3943		0.4419	0.3982		0.4535	0.4011		0.4646	0.4035
	0.4344	0.4032		0.4465	0.4071		0.4586	0.4103		0.4700	0.4126
	0.4282	0.4008		0.4404	0.4052		0.4525	0.4087		0.4642	0.4114
J08	0.4203	0.3834	J16	0.4316	0.3873	K08	0.4428	0.3906	K16	0.4538	0.3931
	0.4260	0.3853		0.4373	0.3893		0.4483	0.3918		0.4593	0.3944
	0.4302	0.3943		0.4419	0.3982		0.4535	0.4011		0.4646	0.4035
	0.4243	0.3921		0.4360	0.3962		0.4477	0.3996		0.4590	0.4023

* Notes : (1) The color coordinates measurement tolerance is ± 0.01.

Based on the measuring instruments of Dongbu LED

(2) The chromaticity coordinates refer to CIE 1931 chromaticity diagram.

■ CIE Chromaticity Diagram

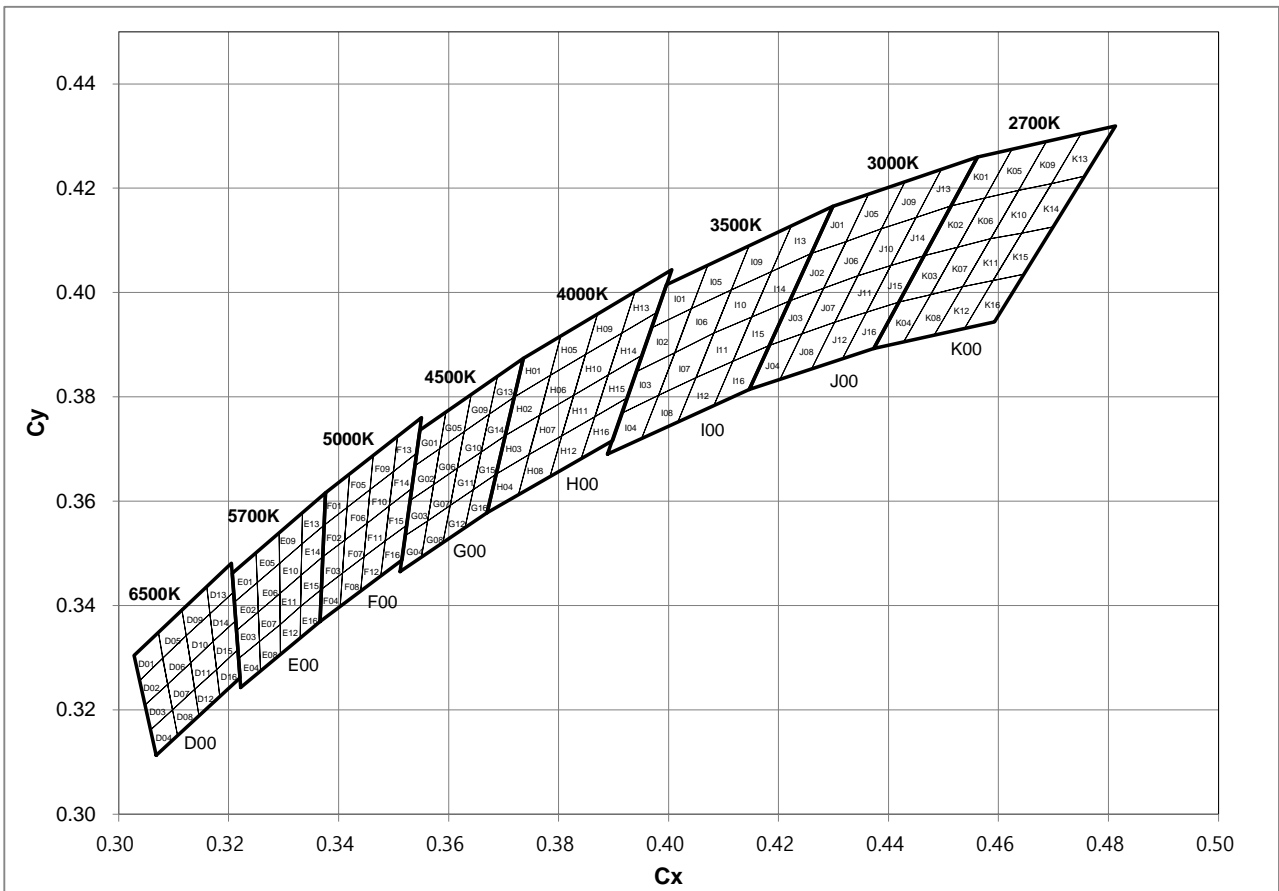

Ex) F00 (5000K) 16 Rank Bin

Ex) F00 (5000K) 5 Rank Bin

Ex) F00 (5000K) 1 Rank Bin

F01	F05	F09	F13
F02	F06	F10	F14
F03	F07	F11	F15
F04	F08	F12	F16

F51	F05	F09	F52
F02	F55	F10	F14
F03	F07	F11	F15
F53	F08	F12	F54

F01	F05	F09	F13
F02	F06	F10	F14
F03	F07	F11	F15
F04	F08	F12	F16

3. Rank Code

The rank inscription is composed of the follow method.

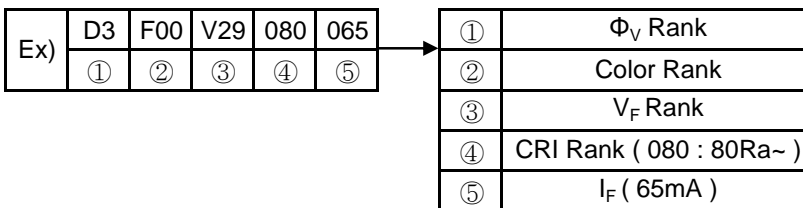

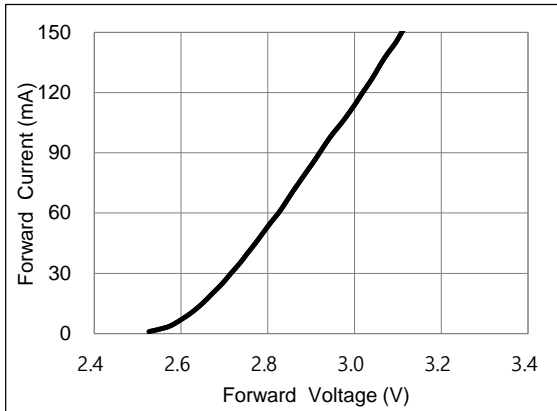
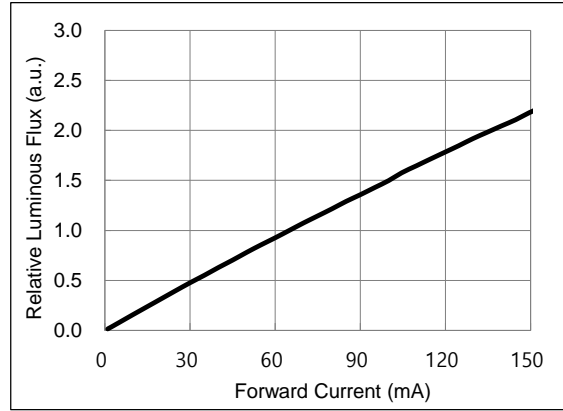
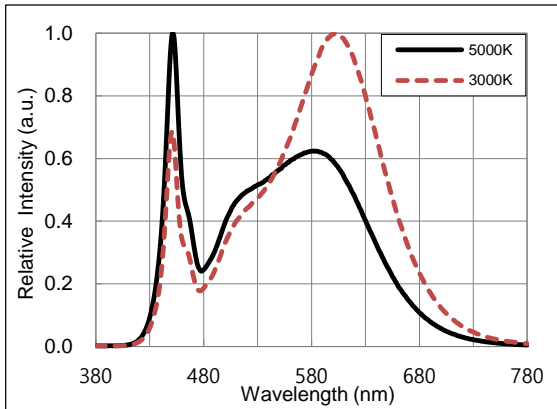
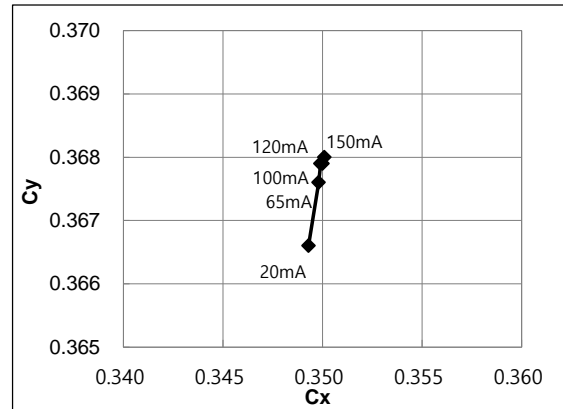
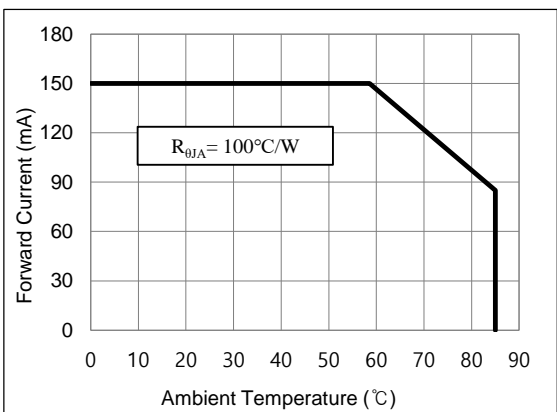
4. Characteristics Diagrams

 Forward Voltage vs Forward Current, $T_a=25^\circ\text{C}$

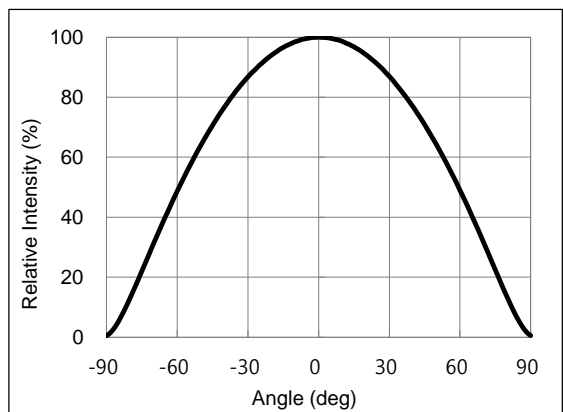
 Forward Current vs Relative Luminous Flux, $T_a=25^\circ\text{C}$

 Spectrum, $T_a=25^\circ\text{C}$, $I_F=65\text{mA}$

 Forward Current vs Chromaticity Coordinate, $T_a=25^\circ\text{C}$

Derating Curve

 Beam Angle, $T_a=25^\circ\text{C}$, $I_F=65\text{mA}$

* Note : The graph of characteristics is the sampling data for the reference.

5. Soldering Conditions

(1) Recommended Soldering Conditions

Conditions	Reflow Soldering		Hand Soldering
	Lead Solder	Lead-Free Solder	
Pre-Heating	120 ~ 150℃	180 ~ 200℃	Temperature Soldering time 300℃ Max. 3 sec. Max. (one time only)
Pre-Heat Time	120sec. Max.	120sec. Max.	
Peak Temperature	240℃ Max.	260℃ Max.	
Soldering Time	5sec. Max.	5sec. Max.	

* After reflow soldering, rapid cooling should be avoid.

(2) Recommended Reflow Soldering Profile

■ Lead Solder

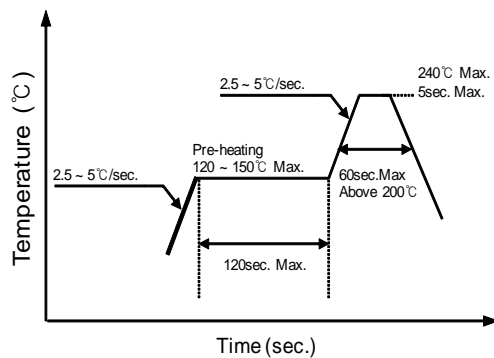

■ Lead Free Solder

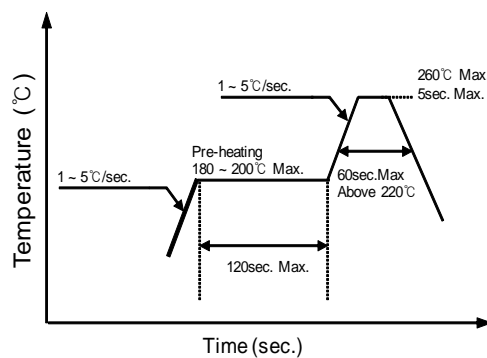

(3) Recommended Soldering Pad Pattern

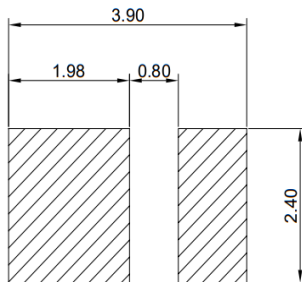

(Unit : mm)

(4) Soldering Cautions

- Reflow soldering should not be done more than two times.
- When soldering, do not put stress on the LEDs during heating.
- After soldering, do not wrap the circuit board.
- The LEDs can be soldered on place using the reflow soldering method.
- Occasionally there is a brightness decrease cause by the influence of heat or ambient atmosphere during air reflow. It is recommend that the user use the nitrogen reflow method.
- After complete soldering, the product should be handled after cooling. (required to be handled under 60℃)

6. Packing

(1) Carrier Tape & Carrier Reel Dimensions

■ Carrier Tape

(Unit : mm)

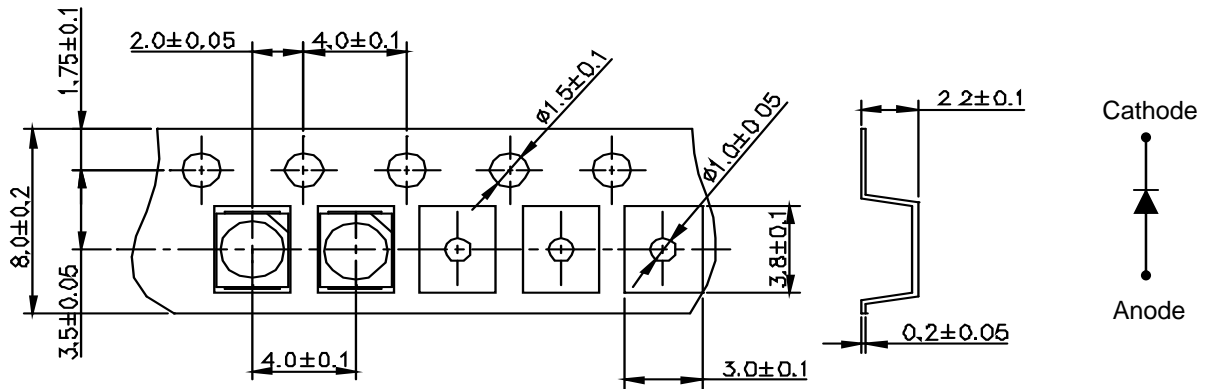

■ Carrier Reel

(Unit : mm)

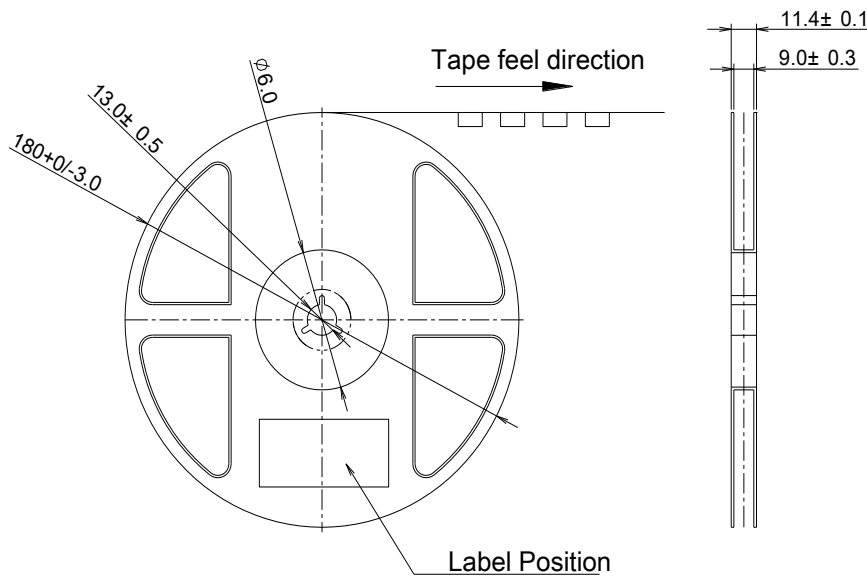

< 7" Reel >

* Notes

- 1) Quantity : Taping of 1 reel will be from 1,000 pcs to 3,000 pcs in unit of a number in the thousands.
- 2) Adhesion strength of cover tape is 0.1 ~ 0.7N(20gf ~60gf) when the cover tape is turned off from the carrier tape.

(2) Packing and Packaging

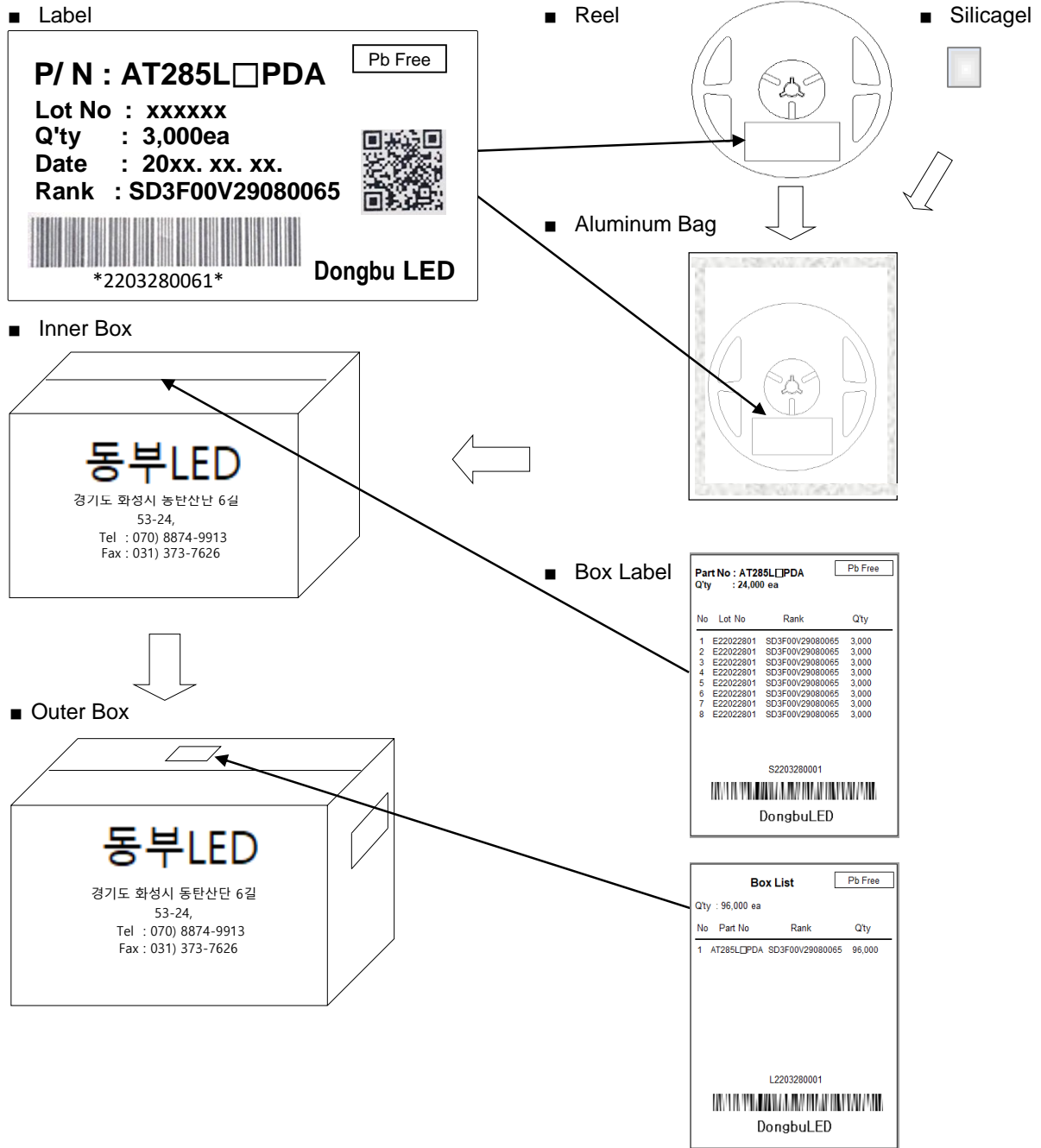

Box Type	Inner Box	Outer Box	
		Medium	Large
Max. Packing Q'ty(pcs)	24,000	96,000	192,000

1) The carrier tape winded on the reel are placed into an ESD protected pack with a silicagel and sealed by the thermal pressure sealer. Then this sealed pack is packaged in a cardboard box.

7. Precaution

(1) Static Electricity

These LEDs are highly susceptible to static electricity or surge voltage. So a wrist strap or an anti-electrostatic glove necessarily be used when handling the LEDs.

Do not use the equipment that surge voltage is came into existence.

All devices and equipment that measure or mount the LEDs must be properly grounded.

After being assembled LEDs, it should be ascertained a electrical characteristic whether that are damaged by static electricity or not.

(2) Packing

The moisture that is absorbed into the LED products may cause a badness and damage to the optical characteristics of the LEDs. Therefore the moisture barrier aluminum bag is used to keep moisture in the packing. And a silicagel is inserted into a moisture barrier aluminum bag that sealed by the thermal pressure sealer.

(3) Cleaning

Ethanol can be used for LED cleaning. The maximum exposure time with ethanol is 1 minute for cleaning.

Do not use ultrasonic for cleaning the LEDs or other solvents, If ultrasonic cleaning is absolutely necessary, a pre-test should be done before cleaning to see if the LED is damaged.

(4) Storage

In order to avoid the absorption of moisture, it is recommended to store LEDs in the moisture barrier aluminum bag is not opened.

Storage condition before opening the packing :

Temperature : below 30℃

Humidity : 90%RH max

The LEDs should be used within a year.

Storage condition after opening the packing :

Temperature : below 30℃

Humidity : 60%RH max

The products have to be used within one year from the date marked on label which is attached to reel or aluminium bag. After opening the packing, the LEDs should be used within 168 hours(7days). If unused LEDs remain, they should be stored in the place kept away moisture.

If the LEDs have exceeded the above storage time, it should be used after to bake using the following conditions.

Baking condition : 60±5℃, 10 ~ 24 hours

A slight amount of sulfur, chlorine or VOC from the surrounding environment may cause discoloration of the LEDs.

(5) Pick and Place

It should be avoided to rub or scratch the surface of resin by any hard material. It is possible that the LEDs are damaged to the optical characteristics.

(6) Heat

The LEDs are products that are generated heat. It must be considered the heat generation of the LEDs when it is designed the PCB. After considering the ambient temperature and the heat generation of LEDs, the operating current should be decided .

(7) Others

If the forward or reverse voltage which exceeds the absolute maximum rating is applied to the LEDs, that will cause the damage to the LEDs. It is possible that the damaged LEDs do not light on at the current.

Be careful not to look the LEDs that the output power is strongly increased in the face. It is possible that eyesight has been getting weaker.

Light emitting part should not be exposed by physical contact. It can be the reason of material desquamation and progressive disconnection.

This LED is made for in-door use only. If the user wants the LED for out-door use, it is necessary to take some additional treatment on the product after surface mounting technology(SMT).

This specification could be changed without a notice to the customer because of the inside circumstance of the company.