

# S P E C I F I C A T I O N S

## SMD TYPE SIDE VIEW WHITE LED MODEL : AS492TWPE1

Dongbu LED Co., Ltd.  
53-24 , Dongtansandan 6-gil , Hwaseong-si , Gyeonggi-do , Republic of Korea 18487  
Tel. : +82 - 70 - 8874 - 9943 Fax. : +82 - 31 - 373 - 7626  
[http : //www.dongbuled-s.com](http://www.dongbuled-s.com)

## 1. General Description

### (1) Features

- Package size - 3.0(L) × 0.85(W) × 0.4(T) mm
- White emission package (Side View)
- Wide beam angle ( $2\theta_{1/2}=120\text{deg}$ )
- RoHS Compliant

### (2) Applications

- Mobile phone , PDA , Indicator , Backlighting etc.

### (3) Outline Dimensions

[ Tolerance :  $\pm 0.1$ , unit : mm ]

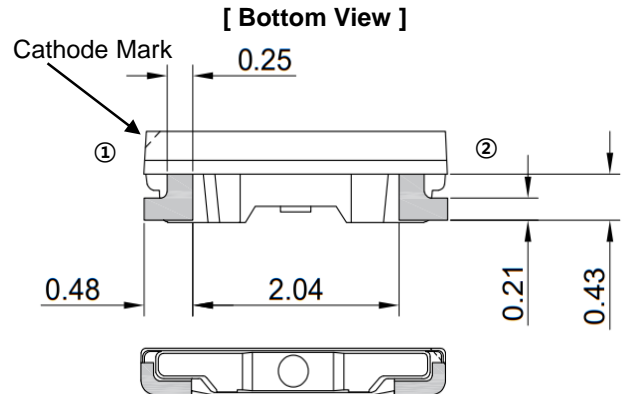
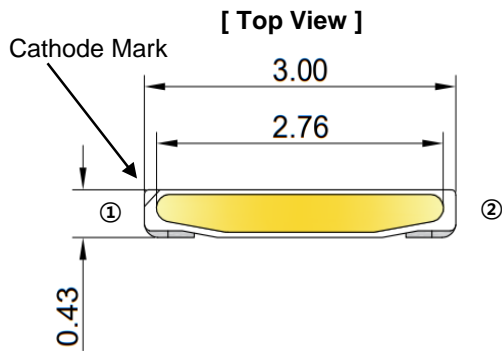

### [ Side View ]

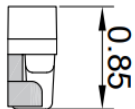

### [ Circuit ]



Cathode

Anode

## 2. Specifications

### (1) Absolute Maximum Ratings

(T<sub>a</sub>=25°C)

Parameter	Symbol	Absolute Maximum Rating	Unit	Remark
Power Dissipation	P <sub>D</sub>	93	mW	
Forward Current	I <sub>F</sub>	30	mA	
Operating Temperature	T <sub>OPR</sub>	-30 to +85	°C	
Storage Temperature	T <sub>STG</sub>	-40 to +100	°C	
Junction Temperature	T <sub>J</sub>	120	°C	

### (2) Initial Electrical/Optical Characteristics

(T<sub>a</sub>=25°C)

Parameter	Symbol	Condition	Min.	Typ.	Max.	Unit
Forward Voltage	V <sub>F</sub>	I <sub>F</sub> = 20mA	2.7	-	3.1	V
Luminous Intensity	I <sub>V</sub>	I <sub>F</sub> = 20mA	2,300	2,800	3,300	mcd
Reverse Current	I <sub>R</sub>	V <sub>R</sub> = 5V	-	-	10	μA
Chromaticity Coordinate	C <sub>x</sub>	I <sub>F</sub> = 20mA	-	0.2850	-	-
	C <sub>y</sub>		-	0.2750	-	-
Beam Angle	2θ <sub>½</sub>	I <sub>F</sub> = 20mA	X - X : 120			deg
			Y - Y : 120			

\* Note : Initial electrical/optical characteristics data could be changeable if the user use the product in different condition besides above data.

### (3) Characteristics Rank

#### ■ Forward Voltage Rank

(I<sub>F</sub> = 20mA, T<sub>a</sub>=25°C)

Symbol	Rank	Min.	Max.	Unit
V <sub>F</sub>	V27	2.7	2.8	V
	V28	2.8	2.9	
	V29	2.9	3.0	
	V30	3.0	3.1	

\* Notes : Forward voltage measurement tolerance is ± 0.1V.

Based on the measuring instruments of Dongbu LED

■ Luminous Intensity Rank

( $I_F = 20\text{mA}$ ,  $T_a = 25^\circ\text{C}$ )

Symbol	Rank	Min.	Max.	Unit
I <sub>v</sub>	230	2,300	2,400	mcd
	240	2,400	2,500	
	250	2,500	2,600	
	260	2,600	2,700	
	270	2,700	2,800	
	280	2,800	2,900	
	290	2,900	3,000	
	300	3,000	3,100	
	310	3,100	3,200	
	320	3,200	3,300	

\* Notes : Luminous intensity measurement tolerance is  $\pm 5\%$ .

Based on the measuring instruments of Dongbu LED

■ Color Rank

( $I_F = 20\text{mA}$ ,  $T_a = 25^\circ\text{C}$ )

A1		A2		A3		A4		A5	
Cx	Cy	Cx	Cy	Cx	Cy	Cx	Cy	Cx	Cy
0.2600	0.2460	0.2685	0.2495	0.2680	0.2380	0.2760	0.2410	0.2760	0.2300
0.2648	0.2538	0.2640	0.2420	0.2723	0.2453	0.2720	0.2340	0.2798	0.2368
0.2685	0.2495	0.2680	0.2380	0.2760	0.2410	0.2760	0.2300	0.2835	0.2325
0.2640	0.2420	0.2723	0.2453	0.2720	0.2340	0.2798	0.2368	0.2800	0.2260

B1		B2		B3		B4		B5	
Cx	Cy	Cx	Cy	Cx	Cy	Cx	Cy	Cx	Cy
0.2648	0.2538	0.2730	0.2570	0.2723	0.2453	0.2800	0.2480	0.2798	0.2368
0.2695	0.2615	0.2685	0.2495	0.2765	0.2525	0.2760	0.2410	0.2835	0.2435
0.2730	0.2570	0.2723	0.2453	0.2800	0.2480	0.2798	0.2368	0.2870	0.2390
0.2685	0.2495	0.2765	0.2525	0.2760	0.2410	0.2835	0.2435	0.2835	0.2325

C1		C2		C3		C4		C5	
Cx	Cy	Cx	Cy	Cx	Cy	Cx	Cy	Cx	Cy
0.2695	0.2615	0.2775	0.2645	0.2765	0.2525	0.2840	0.2550	0.2835	0.2435
0.2743	0.2693	0.2730	0.2570	0.2808	0.2598	0.2800	0.2480	0.2873	0.2503
0.2775	0.2645	0.2765	0.2525	0.2840	0.2550	0.2835	0.2435	0.2905	0.2455
0.2730	0.2570	0.2808	0.2598	0.2800	0.2480	0.2873	0.2503	0.2870	0.2390

■ Color Rank

( $I_F = 20\text{mA}$ ,  $T_a = 25^\circ\text{C}$ )

D1		D2		D3		D4		D5	
Cx	Cy	Cx	Cy	Cx	Cy	Cx	Cy	Cx	Cy
0.2743	0.2693	0.2820	0.2720	0.2808	0.2598	0.2880	0.2620	0.2873	0.2503
0.2790	0.2770	0.2775	0.2645	0.2850	0.2670	0.2840	0.2550	0.2910	0.2570
0.2820	0.2720	0.2808	0.2598	0.2880	0.2620	0.2873	0.2503	0.2940	0.2520
0.2775	0.2645	0.2850	0.2670	0.2840	0.2550	0.2910	0.2570	0.2905	0.2455

E1		E2		E3		E4		E5	
Cx	Cy	Cx	Cy	Cx	Cy	Cx	Cy	Cx	Cy
0.2790	0.2770	0.2865	0.2795	0.2850	0.2670	0.2920	0.2690	0.2910	0.2570
0.2837	0.2847	0.2820	0.2720	0.2893	0.2743	0.2880	0.2620	0.2948	0.2638
0.2865	0.2795	0.2850	0.2670	0.2920	0.2690	0.2910	0.2570	0.2975	0.2585
0.2820	0.2720	0.2893	0.2743	0.2880	0.2620	0.2948	0.2638	0.2940	0.2520

F1		F2		F3		F4		F5	
Cx	Cy	Cx	Cy	Cx	Cy	Cx	Cy	Cx	Cy
0.2837	0.2847	0.2910	0.2870	0.2893	0.2743	0.2960	0.2760	0.2948	0.2638
0.2885	0.2925	0.2865	0.2795	0.2935	0.2815	0.2920	0.2690	0.2985	0.2705
0.2910	0.2870	0.2893	0.2743	0.2960	0.2760	0.2948	0.2638	0.3010	0.2650
0.2865	0.2795	0.2935	0.2815	0.2920	0.2690	0.2985	0.2705	0.2975	0.2585

G1		G2		G3		G4		G5	
Cx	Cy	Cx	Cy	Cx	Cy	Cx	Cy	Cx	Cy
0.2885	0.2925	0.2950	0.2940	0.2935	0.2815	0.3000	0.2830	0.2985	0.2705
0.2925	0.2995	0.2910	0.2870	0.2975	0.2885	0.2960	0.2760	0.3025	0.2775
0.2950	0.2940	0.2935	0.2815	0.3000	0.2830	0.2985	0.2705	0.3050	0.2720
0.2910	0.2870	0.2975	0.2885	0.2960	0.2760	0.3025	0.2775	0.3010	0.2650

H1		H2		H3		H4		H5	
Cx	Cy	Cx	Cy	Cx	Cy	Cx	Cy	Cx	Cy
0.2925	0.2995	0.2990	0.3010	0.2975	0.2885	0.3040	0.2900	0.3025	0.2775
0.2965	0.3065	0.2950	0.2940	0.3015	0.2955	0.3000	0.2830	0.3065	0.2845
0.2990	0.3010	0.2975	0.2885	0.3040	0.2900	0.3025	0.2775	0.3090	0.2790
0.2950	0.2940	0.3015	0.2955	0.3000	0.2830	0.3065	0.2845	0.3050	0.2720

■ Color Rank

( $I_F = 20\text{mA}$ ,  $T_a = 25^\circ\text{C}$ )

I1		I2		I3		I4		I5	
Cx	Cy	Cx	Cy	Cx	Cy	Cx	Cy	Cx	Cy
0.2965	0.3065	0.3030	0.3080	0.3015	0.2955	0.3080	0.2970	0.3065	0.2845
0.3005	0.3135	0.2990	0.3010	0.3055	0.3025	0.3040	0.2900	0.3105	0.2915
0.3030	0.3080	0.3015	0.2955	0.3080	0.2970	0.3065	0.2845	0.3130	0.2860
0.2990	0.3010	0.3055	0.3025	0.3040	0.2900	0.3105	0.2915	0.3090	0.2790

J1		J2		J3		J4		J5	
Cx	Cy	Cx	Cy	Cx	Cy	Cx	Cy	Cx	Cy
0.3005	0.3135	0.3070	0.3150	0.3055	0.3025	0.3120	0.3040	0.3105	0.2915
0.3045	0.3205	0.3030	0.3080	0.3095	0.3095	0.3080	0.2970	0.3145	0.2985
0.3070	0.3150	0.3055	0.3025	0.3120	0.3040	0.3105	0.2915	0.3170	0.2930
0.3030	0.3080	0.3095	0.3095	0.3080	0.2970	0.3145	0.2985	0.3130	0.2860

K1		K2		K3		K4		K5	
Cx	Cy	Cx	Cy	Cx	Cy	Cx	Cy	Cx	Cy
0.3045	0.3205	0.3070	0.3150	0.3095	0.3095	0.3120	0.3040	0.3145	0.2985
0.3085	0.3275	0.3110	0.3220	0.3135	0.3165	0.3160	0.3110	0.3185	0.3055
0.3110	0.3220	0.3135	0.3165	0.3160	0.3110	0.3185	0.3055	0.3210	0.3000
0.3070	0.3150	0.3095	0.3095	0.3120	0.3040	0.3145	0.2985	0.3170	0.2930

L1		L2		L3		L4		L5	
Cx	Cy	Cx	Cy	Cx	Cy	Cx	Cy	Cx	Cy
0.3085	0.3275	0.3110	0.3220	0.3135	0.3165	0.3160	0.3110	0.3185	0.3055
0.3125	0.3345	0.3150	0.3290	0.3175	0.3235	0.3200	0.3180	0.3225	0.3125
0.3150	0.3290	0.3175	0.3235	0.3200	0.3180	0.3225	0.3125	0.3250	0.3070
0.3110	0.3220	0.3135	0.3165	0.3160	0.3110	0.3185	0.3055	0.3210	0.3000

\* Notes : (1) Chromaticity coordinates measurement tolerance is  $\pm 0.005$ .

Based on the measuring instruments of Dongbu LED

(2) The chromaticity coordinates refer to CIE 1931 chromaticity diagram.

■ CIE Chromaticity Diagram

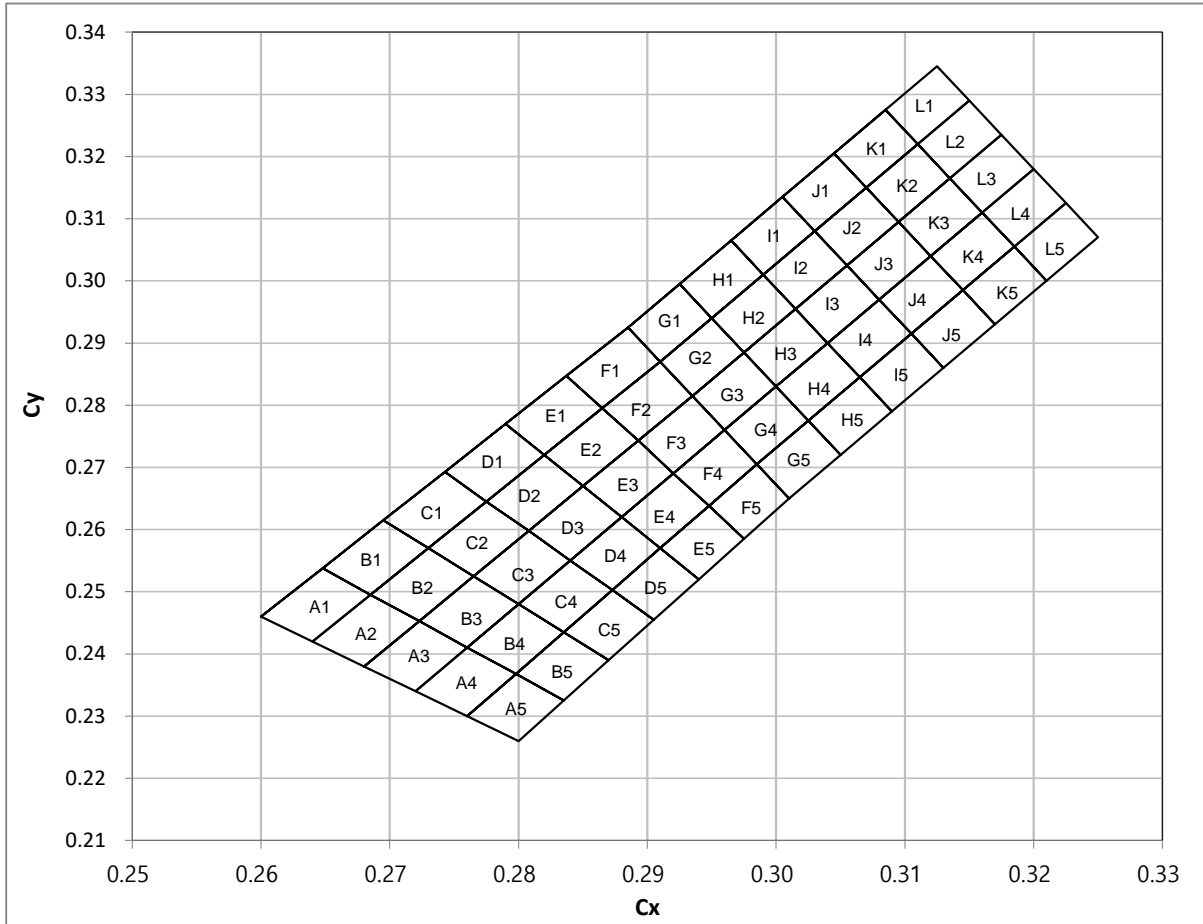

**3. Rank Code**

The rank inscription is composed of the follow method.

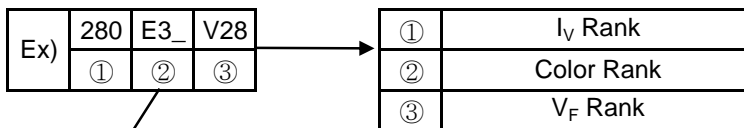

- S : Used 4 rank in one rank → E3S
- D : Used 2 vertical rank in one rank → E3D
- R : Used 2 horizontal rank in one rank → E3R

4. Characteristics Diagrams

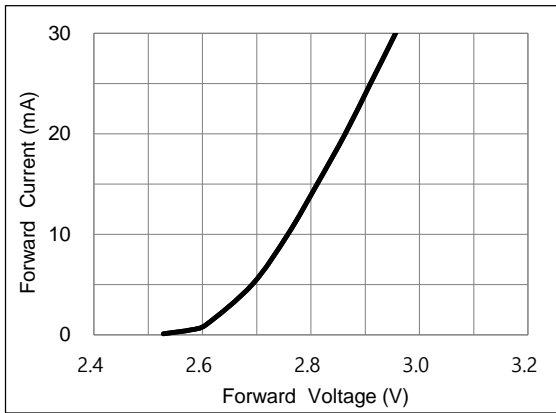

Forward Voltage vs Forward Current,  $T_a=25^\circ\text{C}$

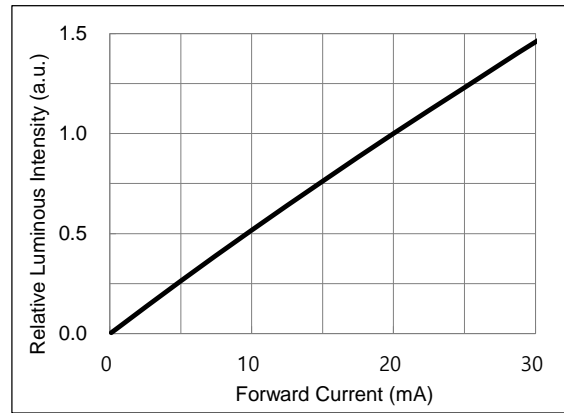

Forward Current vs Relative Luminous Intensity,  $T_a=25^\circ\text{C}$

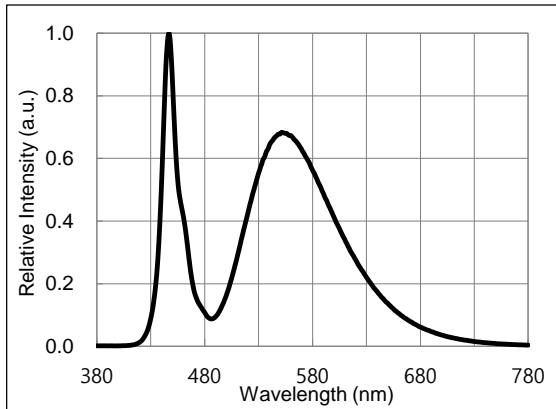

Spectrum,  $T_a=25^\circ\text{C}$ ,  $I_F=20\text{mA}$

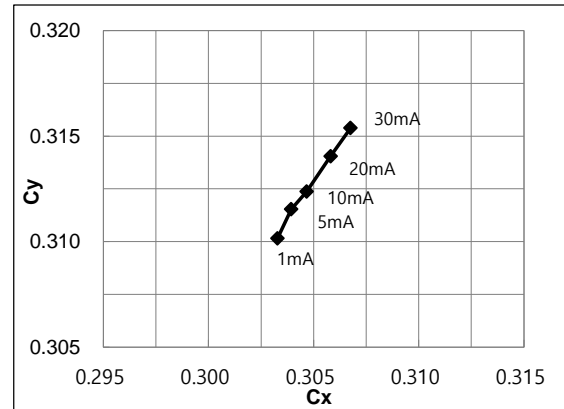

Forward Current vs Chromaticity Coordinate,  $T_a=25^\circ\text{C}$

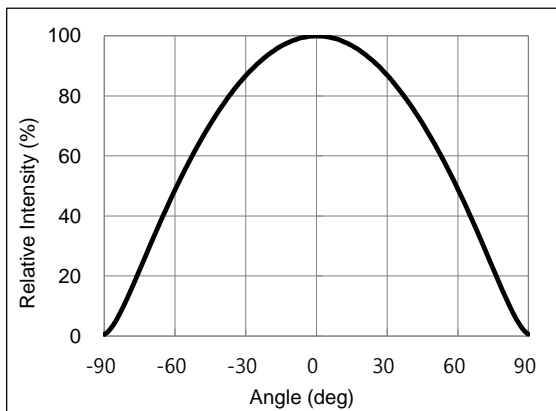

Beam Angle,  $T_a=25^\circ\text{C}$ ,  $I_F=20\text{mA}$

\* Note : The graph of characteristics is the sampling data for the reference.



## 5. Results of Reliability Tests

### (1) Test Items and Results

Item	Test Condition	Notes	No. of Damaged
Temperature Cycle	-40℃ ~25℃ ~100℃ ~25℃ (30min~5min~30min~5min)	100 cycles	0/50
Steady State Operating Life	T <sub>a</sub> = 25℃, I <sub>F</sub> = 20mA	1000 hrs	0/50
Steady State Operating Life of High Temperature	T <sub>a</sub> = 85℃, I <sub>F</sub> = 20mA	1000 hrs	0/50
Steady State Operating Life of High Humidity Heat	T <sub>a</sub> = 60℃, RH = 90%, I <sub>F</sub> = 20mA	1000 hrs	0/50
Steady State Operating Life of Low Temperature	T <sub>a</sub> = -30℃, I <sub>F</sub> = 20mA	1000 hrs	0/50
High Temperature Storage	T <sub>a</sub> = 100℃	1000 hrs	0/50
High Temperature & Humidity Storage	T <sub>a</sub> = 60℃, RH = 90%	1000 hrs	0/50
Low Temperature Storage	T <sub>a</sub> = -40℃	1000 hrs	0/50
Resistance to Soldering Heat	T <sub>max</sub> =260℃, 10sec (Pre treatment 30℃, 70%, 168hrs)	2 times	0/50

\* The above reliability data is only for the reference data about the environment test.

### (2) Criteria for Judging the Damage

Parameter	Symbol	Condition	Criteria for Judgement
Forward Voltage	V <sub>F</sub>	I <sub>F</sub> = 20mA	Max. Initial Value*1.2
Luminous Intensity	I <sub>V</sub>	I <sub>F</sub> = 20mA	Min. Initial Value*0.7

## 6. Soldering Conditions

### (1) Recommended Soldering Conditions

Conditions	Reflow Soldering		Hand Soldering
	Lead Solder	Lead-Free Solder	
Pre-Heating	120 ~ 150°C	180 ~ 200°C	Temperature Soldering time 300°C Max. 3 sec. Max. (one time only)
Pre-Heat Time	120sec. Max.	120sec. Max.	
Peak Temperature	240°C Max.	260°C Max.	
Soldering Time	5sec. Max.	5sec. Max.	

\* After reflow soldering, rapid cooling should be avoid.

### (2) Recommended Reflow Soldering Profile

#### ■ Lead Solder

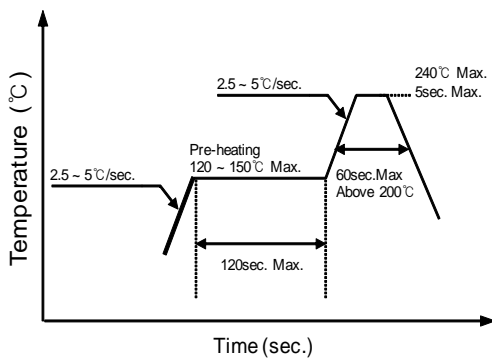

#### ■ Lead Free Solder

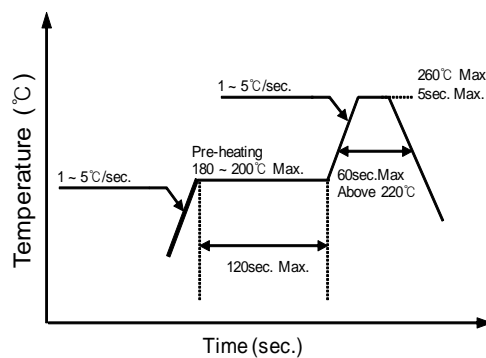

### (3) Recommended Soldering Pad Pattern

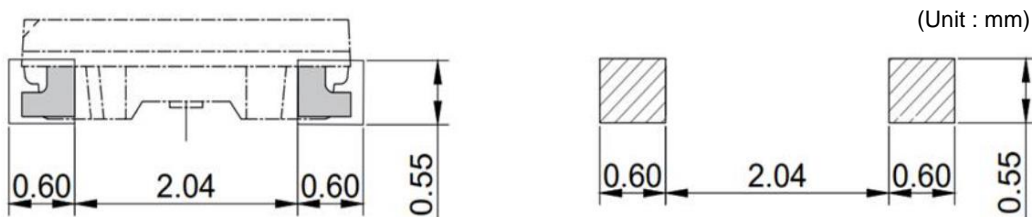

### (4) Soldering Cautions

- Reflow soldering should not be done more than two times.
- When soldering, do not put stress on the LEDs during heating.
- After soldering, do not wrap the circuit board.
- The LEDs can be soldered on place using the reflow soldering method.
- Occasionally there is a brightness decrease cause by the influence of heat or ambient atmosphere during air reflow. It is recommend that the user use the nitrogen reflow method.
- After complete soldering, the product should be handled after cooling. (required to be handled under 60°C)

**7. Packing**

**(1) Carrier Tape & Carrier Reel Dimensions**

■ Carrier Tape

( Unit : mm )

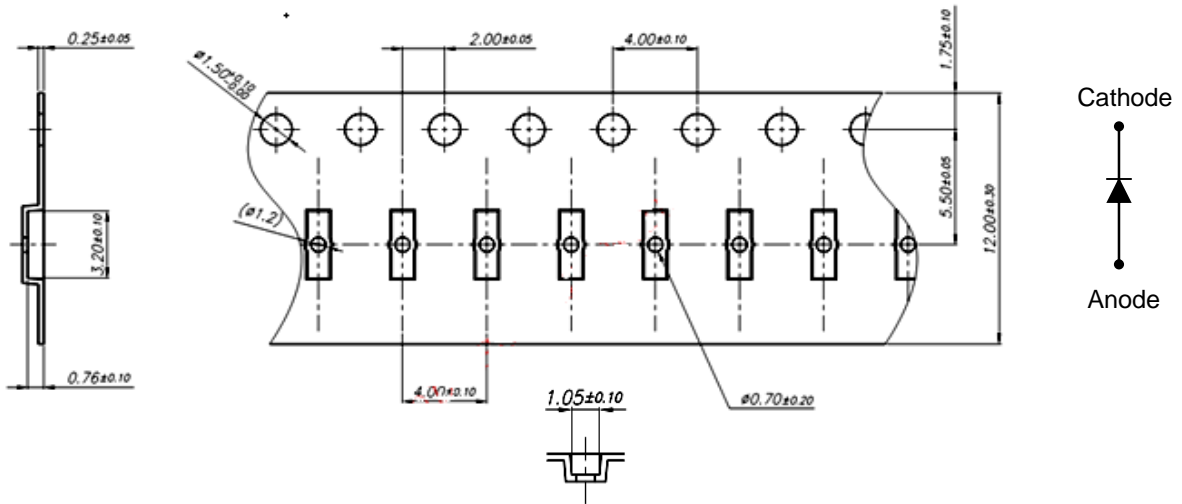

■ Carrier Reel

( Unit : mm )

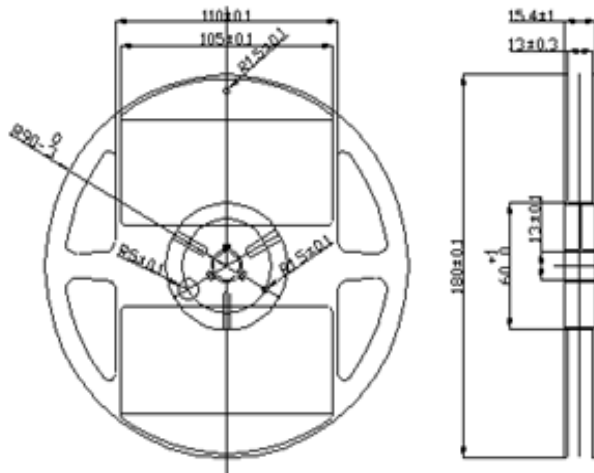

< 7" Reel >

- 1) Quantity : Taping of 1 reel will be from min 500pcs to 5,000pcs in unit of a number in the 5hundreds .
- 2) Adhesion strength of cover tape is 0.1 ~ 0.7N(20gf ~60gf) when the cover tape is turned off from the carrier tape.

## (2) Packing and Packaging

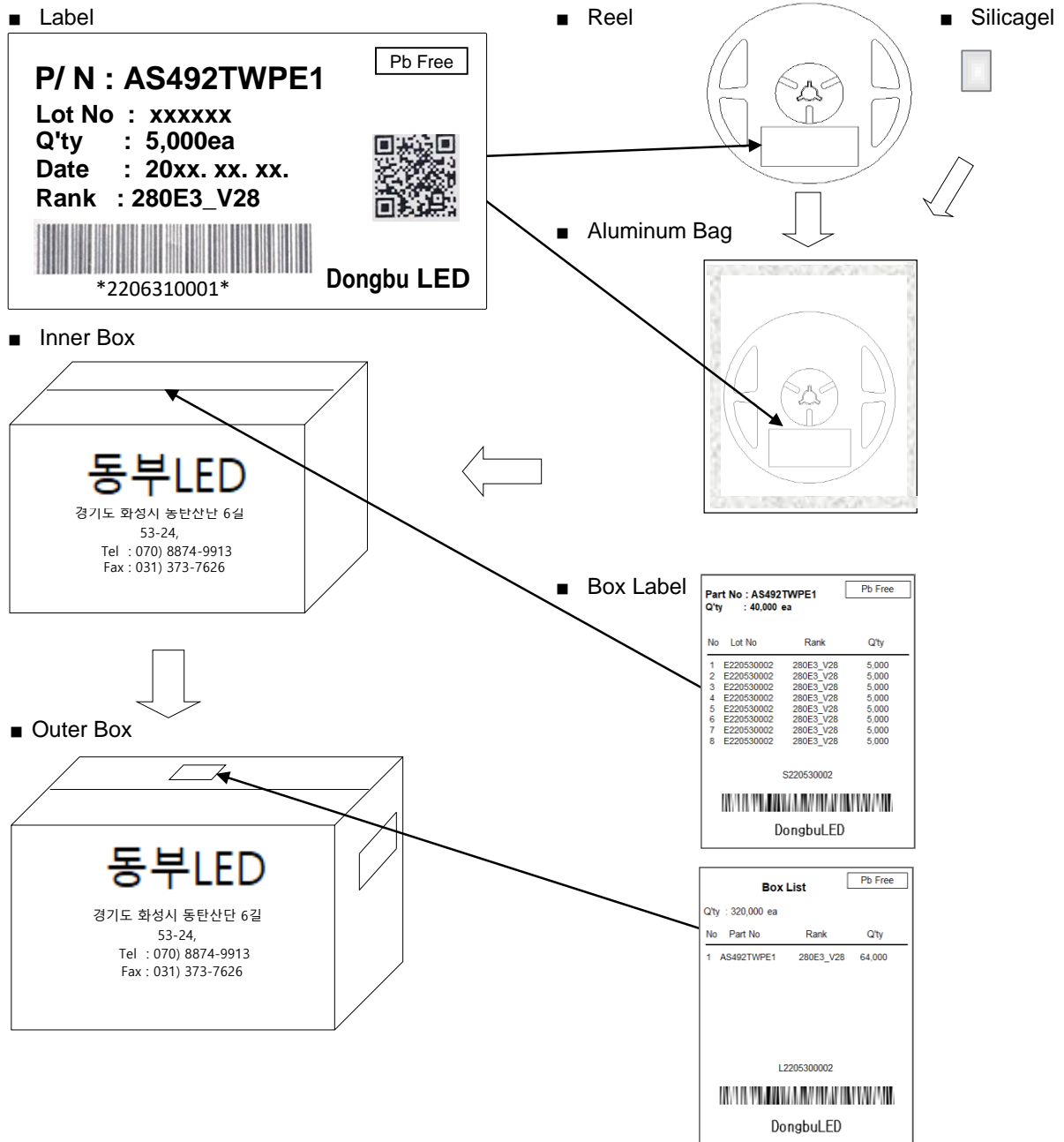

Box Type	Inner Box	Outer Box	
		Medium	Large
Max. Packing Q'ty(pcs)	40,000	160,000	320,000

1) The carrier tape winded on the reel are placed into an ESD protected pack with a silicagel and sealed by the thermal pressure sealer. Then this sealed pack is packaged in a cardboard box.

## 8. Precaution

### (1) Static Electricity

These LEDs are highly susceptible to static electricity or surge voltage. So a wrist strap or an anti-electrostatic glove necessarily be used when handling the LEDs.

Do not use the equipment that surge voltage is came into existence.

All devices and equipment that measure or mount the LEDs must be properly grounded.

After being assembled LEDs, it should be ascertained a electrical characteristic whether that are damaged by static electricity or not.

### (2) Packing

The moisture that is absorbed into the LED products may cause a badness and damage to the optical characteristics of the LEDs. Therefore the moisture barrier aluminum bag is used to keep moisture in the packing. And a silicagel is inserted into a moisture barrier aluminum bag that sealed by the thermal pressure sealer.

### (3) Cleaning

Ethanol can be used for LED cleaning. The maximum exposure time with ethanol is 1 minute for cleaning.

Do not use ultrasonic for cleaning the LEDs or other solvents, If ultrasonic cleaning is absolutely necessary, a pre-test should be done before cleaning to see if the LED is damaged.

### (4) Storage

In order to avoid the absorption of moisture, it is recommended to store LEDs in the moisture barrier aluminum bag is not opened.

Storage condition before opening the packing :

Temperature : below 30℃

Humidity : 90%RH max

The LEDs should be used within a year.

Storage condition after opening the packing :

Temperature : below 30℃

Humidity : 60%RH max

The products have to be used within one year from the date marked on label which is attached to reel or aluminium bag. After opening the packing, the LEDs should be used within 168 hours(7days). If unused LEDs remain, they should be stored in the place kept away moisture.

If the LEDs have exceeded the above storage time, it should be used after to bake using the following conditions.

Baking condition : 60±5℃, 10 ~ 24 hours

A slight amount of sulfur, chlorine or VOC from the surrounding environment may cause discoloration of the LEDs.

**(5) Pick and Place**

It should be avoided to rub or scratch the surface of resin by any hard material. It is possible that the LEDs are damaged to the optical characteristics.

**(6) Heat**

The LEDs are products that are generated heat. It must be considered the heat generation of the LEDs when it is designed the PCB. After considering the ambient temperature and the heat generation of LEDs, the operating current should be decided .

**(7) Others**

If the forward or reverse voltage which exceeds the absolute maximum rating is applied to the LEDs, that will cause the damage to the LEDs. It is possible that the damaged LEDs do not light on at the current.

Be careful not to look the LEDs that the output power is strongly increased in the face. It is possible that eyesight has been getting weaker.

Light emitting part should not be exposed by physical contact. It can be the reason of material desquamation and progressive disconnection.

This LED is made for in-door use only. If the user wants the LED for out-door use, it is necessary to take some additional treatment on the product after surface mounting technology(SMT).

This specification could be changed without a notice to the customer because of the inside circumstance of the company.