

# **PRELIMINARY SPECIFICATIONS**

**SMD TYPE TOP VIEW WHITE LED**

**MODEL : AT722TWANE**

Dongbu LED Co., Ltd.

90-1, Bongmyung-Ri, Namsa-Myun, Cheoin-Gu, Yongin-City, Gyeonggi-Do, Korea 449-882

Tel. : +82 - 31 - 339 - 6400      Fax. : +82 - 31 - 339 - 7651

[http : //www.dongbuled-s.com](http://www.dongbuled-s.com)

## 1. General Description

### (1) Features

- Package Size - 7.0(L) × 2.0(W) × 0.8(T) mm
- Ideal for backlighting and coupling in light guides
- Wide view angle ( $2\theta_{1/2}=120\text{deg.}$ )

### (2) Applications

- Backlighting(LCD, switches, keys, displays)
- Coupling into light guides
- Optical indicator
- Interior automotive lighting

### (3) Outline Dimensions

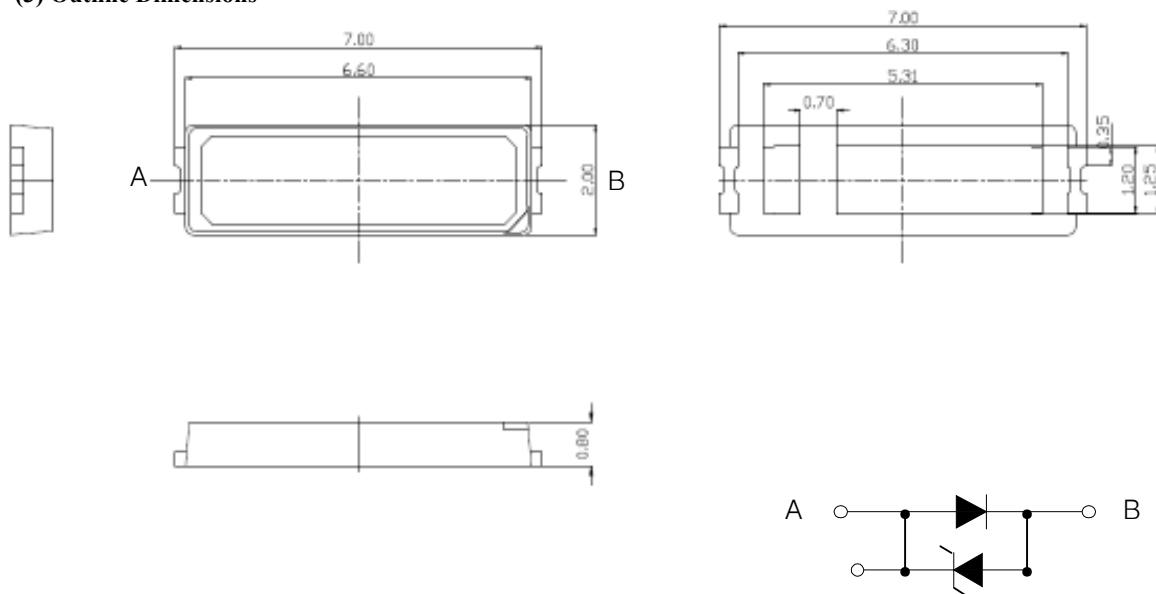

## 2. Specifications

### (1) Absolute maximum ratings (T<sub>a</sub>=25°C)

Parameter	Symbol	Absolute maximum rating	Unit	Remark
Power Dissipation	P <sub>D</sub>	510	mW	
Forward Current	I <sub>F</sub>	150	mA	
Peak Pulse Current <sup>(1)</sup>	I <sub>FP</sub>	350	mA	
Operating Temperature	T <sub>OPR</sub>	-30 to +85	°C	
Storage Temperature	T <sub>STG</sub>	-40 to +100	°C	

Notes (1) Duty ratio = 1/10, pulse with = 10msec

### (2) Initial Electrical/Optical Characteristics (T<sub>a</sub>=25°C)

Parameter	Symbol	Condition	Min.	Typ.	Max.	Unit
Forward Voltage	V <sub>F</sub>	I <sub>F</sub> = 120mA	-	3.2	3.4	V
Luminous Intensity <sup>(1)(2)</sup>	I <sub>V</sub>	I <sub>F</sub> = 120mA	-	14,000	-	mcd
Luminous Flux <sup>(1)(2)</sup>	Φ <sub>V</sub>	I <sub>F</sub> = 120mA	-	43.5	-	lm
Reverse Voltage	V <sub>R</sub>	I <sub>R</sub> = 5mA	0.7	-	1.2	V
Chromaticity Coordinate <sup>(3)</sup>	C <sub>X</sub>	I <sub>F</sub> = 120mA	-	0.280	-	-
	C <sub>Y</sub>		-	0.260	-	-

Notes (1) Luminous Intensity / Flux measuring equipment : CAS140B(Instrument system)

(2) Luminous Intensity / Flux Measurement allowance is ± 5%

(3) The coordinate refer to CIE 1931 chromaticity diagram.

### (3) Characteristics Rank

#### ■ Forward voltage & Luminous intensity rank (T<sub>a</sub>=25°C)

Parameter	Symbol	Condition	Rank	Min.	Max.	Unit
Forward Voltage	V <sub>F</sub>	I <sub>F</sub> = 120mA	Z30	3.0	3.2	V
			Z32	3.2	3.4	
Luminous Intensity	I <sub>V</sub>	I <sub>F</sub> = 120mA	HB0	11,000	11,500	mcd
			HB5	11,500	12,000	
			HC0	12,000	12,500	
			HC5	12,500	13,000	

**■ Color Rank**

	A00			
Cx	0.2688	0.2638	0.2538	0.2588
Cy	0.2094	0.1994	0.1994	0.2094

	B00			
Cx	0.2738	0.2688	0.2588	0.2638
Cy	0.2194	0.2094	0.2094	0.2194

	C00			
Cx	0.2788	0.2738	0.2638	0.2688
Cy	0.2294	0.2194	0.2194	0.2294

	D00			
Cx	0.2838	0.2788	0.2688	0.2738
Cy	0.2394	0.2294	0.2294	0.2394

	E00			
Cx	0.2888	0.2838	0.2738	0.2788
Cy	0.2494	0.2394	0.2394	0.2494

	F00			
Cx	0.2938	0.2888	0.2788	0.2838
Cy	0.2594	0.2494	0.2494	0.2594

	G00			
Cx	0.2988	0.2938	0.2838	0.2888
Cy	0.2694	0.2594	0.2594	0.2694

	H00			
Cx	0.3038	0.2988	0.2888	0.2938
Cy	0.2794	0.2694	0.2694	0.2794

	I00			
Cx	0.3088	0.3038	0.2938	0.2988
Cy	0.2894	0.2794	0.2794	0.2894

	J00			
Cx	0.3138	0.3088	0.2988	0.3038
Cy	0.2994	0.2894	0.2894	0.2994

	K00			
Cx	0.3188	0.3138	0.3038	0.3088
Cy	0.3094	0.2994	0.2994	0.3094

	L00			
Cx	0.3238	0.3188	0.3088	0.3138
Cy	0.3194	0.3094	0.3094	0.3194

	A01			
Cx	0.2588	0.2538	0.2438	0.2488
Cy	0.2094	0.1994	0.1994	0.2094

	B01			
Cx	0.2638	0.2588	0.2488	0.2538
Cy	0.2194	0.2094	0.2094	0.2194

	C01			
Cx	0.2688	0.2638	0.2538	0.2588
Cy	0.2294	0.2194	0.2194	0.2294

	D01			
Cx	0.2738	0.2688	0.2588	0.2638
Cy	0.2394	0.2294	0.2294	0.2394

	E01			
Cx	0.2788	0.2738	0.2638	0.2688
Cy	0.2494	0.2394	0.2394	0.2494

	F01			
Cx	0.2838	0.2788	0.2688	0.2738
Cy	0.2594	0.2494	0.2494	0.2594

	G01			
Cx	0.2888	0.2838	0.2738	0.2788
Cy	0.2694	0.2594	0.2594	0.2694

	H01			
Cx	0.2938	0.2888	0.2788	0.2838
Cy	0.2794	0.2694	0.2694	0.2794

	I01			
Cx	0.2988	0.2938	0.2838	0.2888
Cy	0.2894	0.2794	0.2794	0.2894

J01	J01			
Cx	0.3038	0.2988	0.2888	0.2938
Cy	0.2994	0.2894	0.2894	0.2994

	K01			
Cx	0.3088	0.3038	0.2938	0.2988
Cy	0.3094	0.2994	0.2994	0.3094

	L01			
Cx	0.3138	0.3088	0.2988	0.3038
Cy	0.3194	0.3094	0.3094	0.3194

	A02			
Cx	0.2488	0.2438	0.2338	0.2388
Cy	0.2094	0.1994	0.1994	0.2094

	B02			
Cx	0.2538	0.2488	0.2388	0.2438
Cy	0.2194	0.2094	0.2094	0.2194

	C02			
Cx	0.2588	0.2538	0.2438	0.2488
Cy	0.2294	0.2194	0.2194	0.2294

	D02			
Cx	0.2638	0.2588	0.2488	0.2538
Cy	0.2394	0.2294	0.2294	0.2394

	E02			
Cx	0.2688	0.2638	0.2538	0.2588
Cy	0.2494	0.2394	0.2394	0.2494

	F02			
Cx	0.2738	0.2688	0.2588	0.2638
Cy	0.2594	0.2494	0.2494	0.2594

	G02			
Cx	0.2788	0.2738	0.2638	0.2688
Cy	0.2694	0.2594	0.2594	0.2694

	H02			
Cx	0.2838	0.2788	0.2688	0.2738
Cy	0.2794	0.2694	0.2694	0.2794

	I02			
Cx	0.2888	0.2838	0.2738	0.2788
Cy	0.2894	0.2794	0.2794	0.2894

	J02			
Cx	0.2938	0.2888	0.2788	0.2838
Cy	0.2994	0.2894	0.2894	0.2994

	K02			
Cx	0.2988	0.2938	0.2838	0.2888
Cy	0.3094	0.2994	0.2994	0.3094

	L02			
Cx	0.3038	0.2988	0.2888	0.2938
Cy	0.3194	0.3094	0.3094	0.3194

■ Chromaticity Diagram

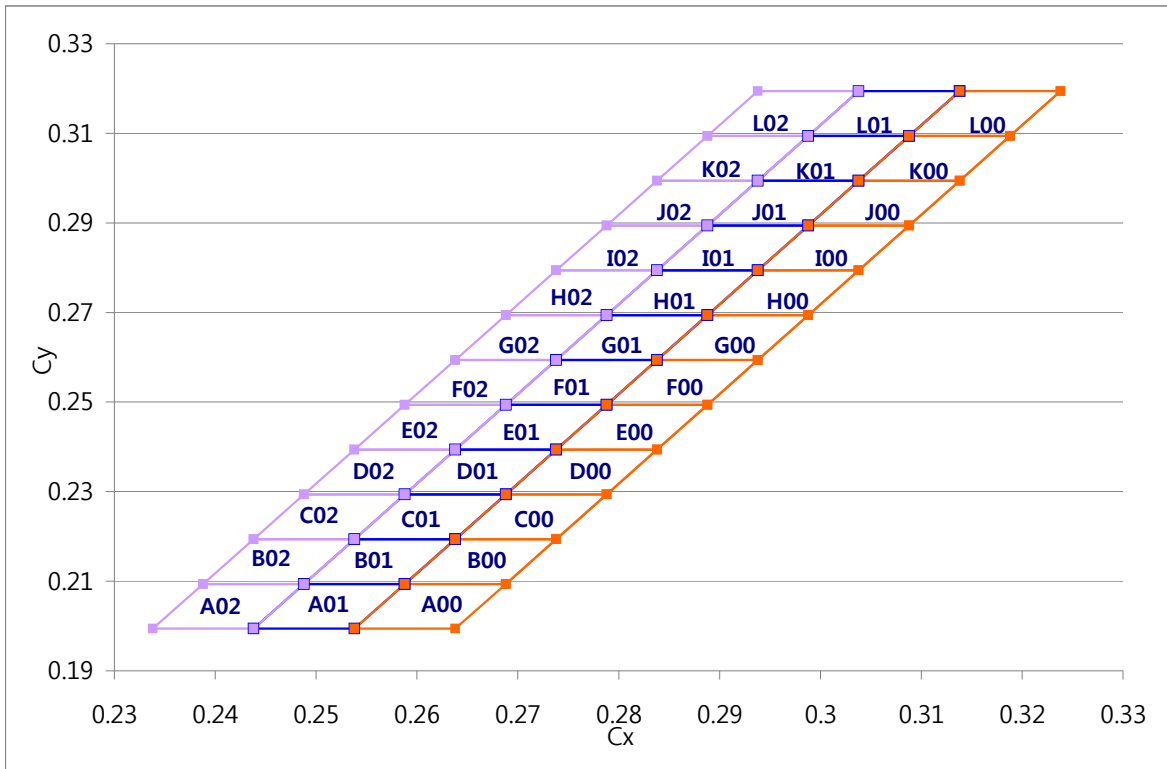

3. Rank

The rank inscription is composed of the method as below

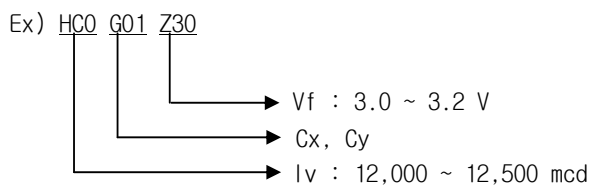

4. Characteristics Diagrams

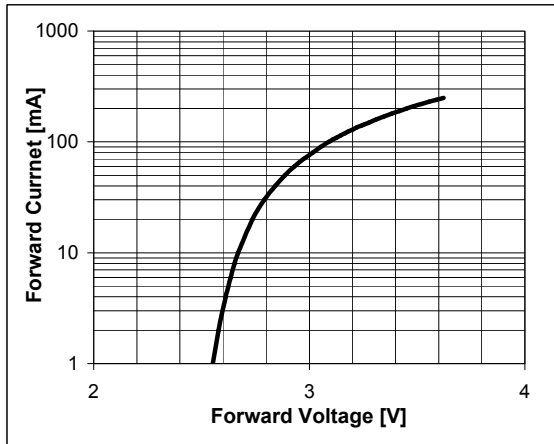

Forward Current vs Forward Voltage

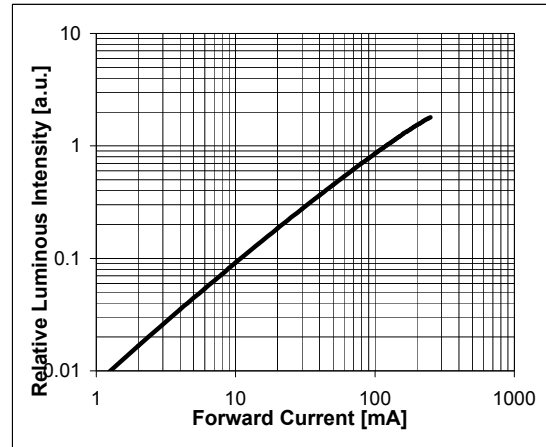

Relative Luminous Intensity vs Forward Current

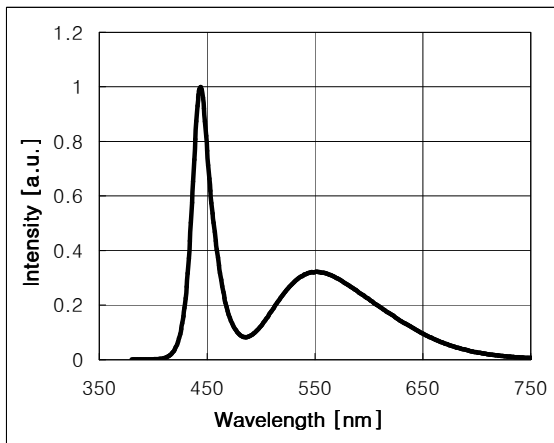

Relative Spectral Emission

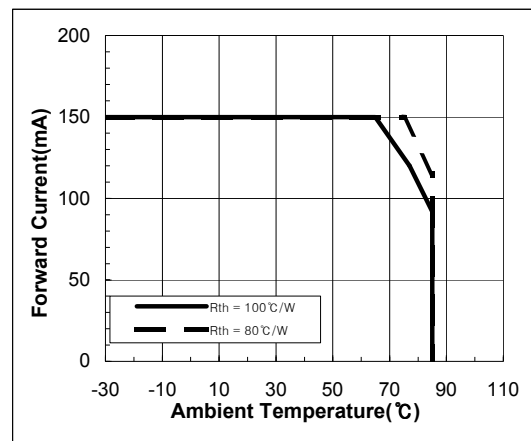

Forward Current Dissipation Curve

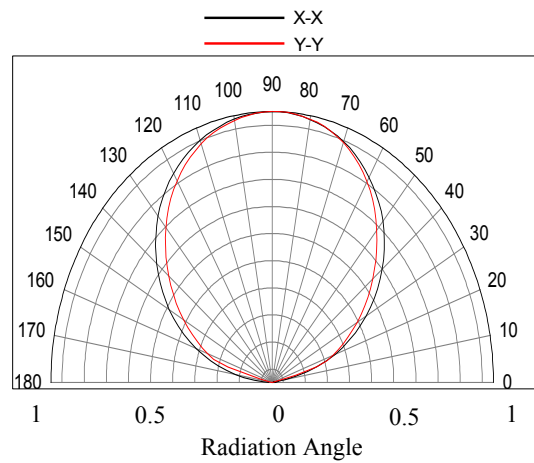

### 5. Soldering Conditions

#### (1) Recommended Soldering Conditions

	Reflow Soldering		Hand Soldering	
	Lead Solder	Lead-Free Solder	Temperature Soldering time	300 °C Max. 3 sec. Max. (one time only)
Pre-Heating	120 ~ 150 °C	180 ~ 200 °C		
Pre-Heat Time	120sec. Max.	120sec. Max.		
Peak Temperature	240 °C Max.	260 °C Max.		
Soldering Time	5sec. Max.	5sec. Max.		

\* After reflow soldering, Rapid cooling should be avoid.

#### (2) Recommended Reflow Soldering profile

##### ■ Lead Solder

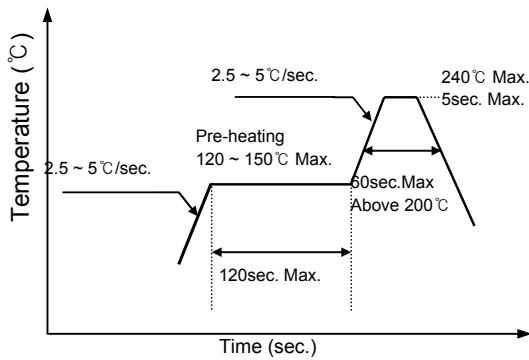

##### ■ Lead-Free Solder

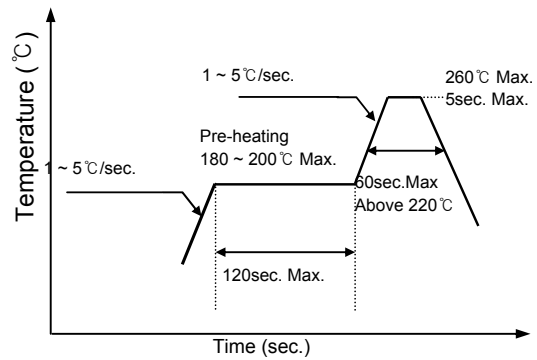

#### (3) Recommended Soldering Pattern

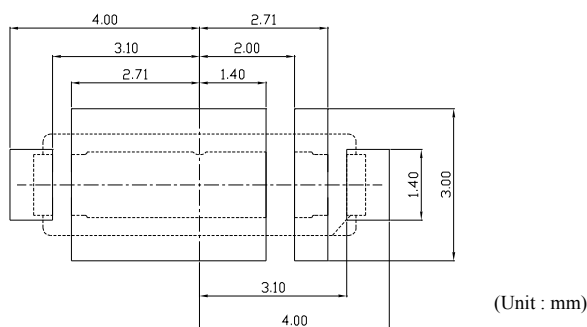

#### (4) Soldering Cautions

- Reflow soldering should not be done more than two times.
- When soldering, do not put stress on the LEDs during heating.
- After soldering, do not wrap the circuit board.
- The LEDs can be soldered on place using the reflow soldering method.
- Occasionally there is a brightness decrease cause by the influence of heat or ambient atmosphere during air reflow. It is recommend that the user use the nitrogen reflow method.



## 6. Packing

### (1) Carrier Tape & Carrier Reel Dimensions

#### ■ Carrier Tape

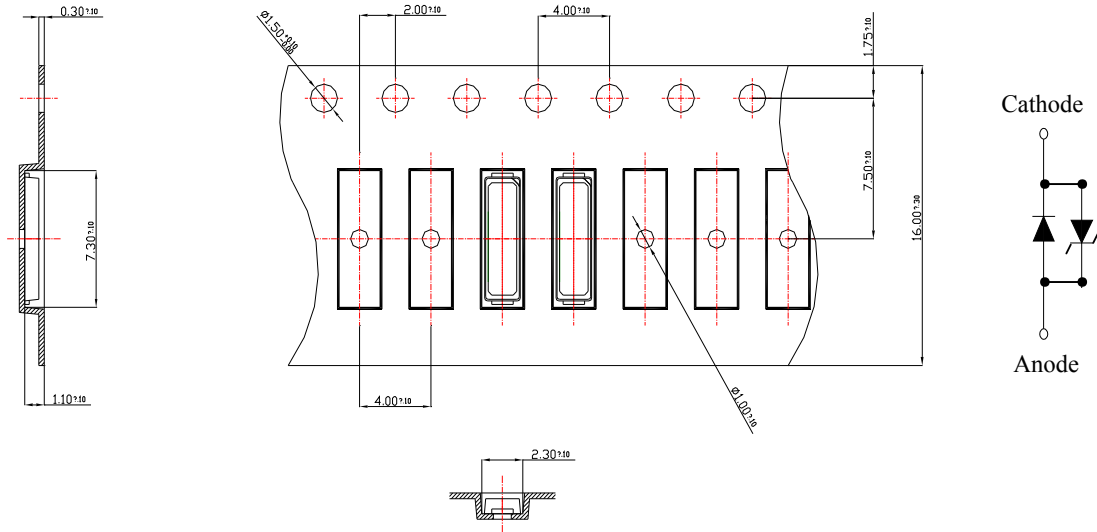

#### ■ Carrier Reel

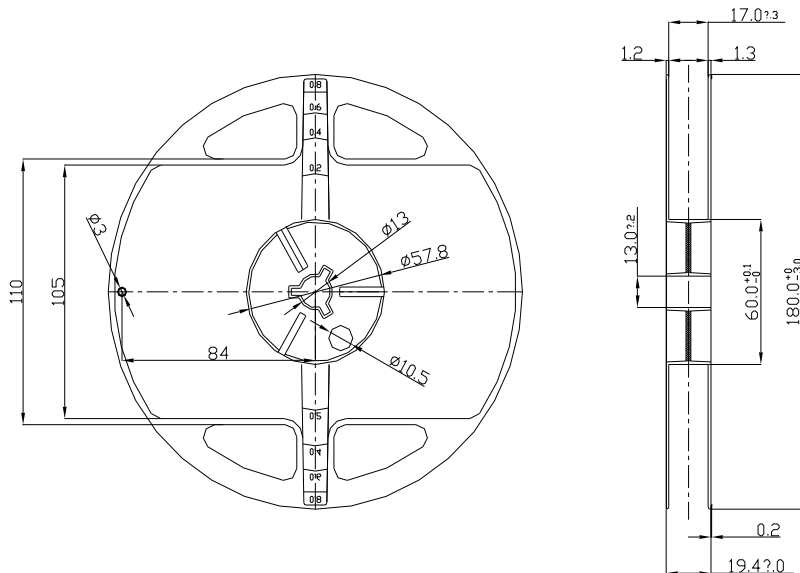

Notes (1) Quantity : 3,000pcs/reel

(2) Adhesion strength of cover tape is 0.1 ~ 0.7N when the cover tape is turned off from the carrier tape.

(2) Packing and Packaging

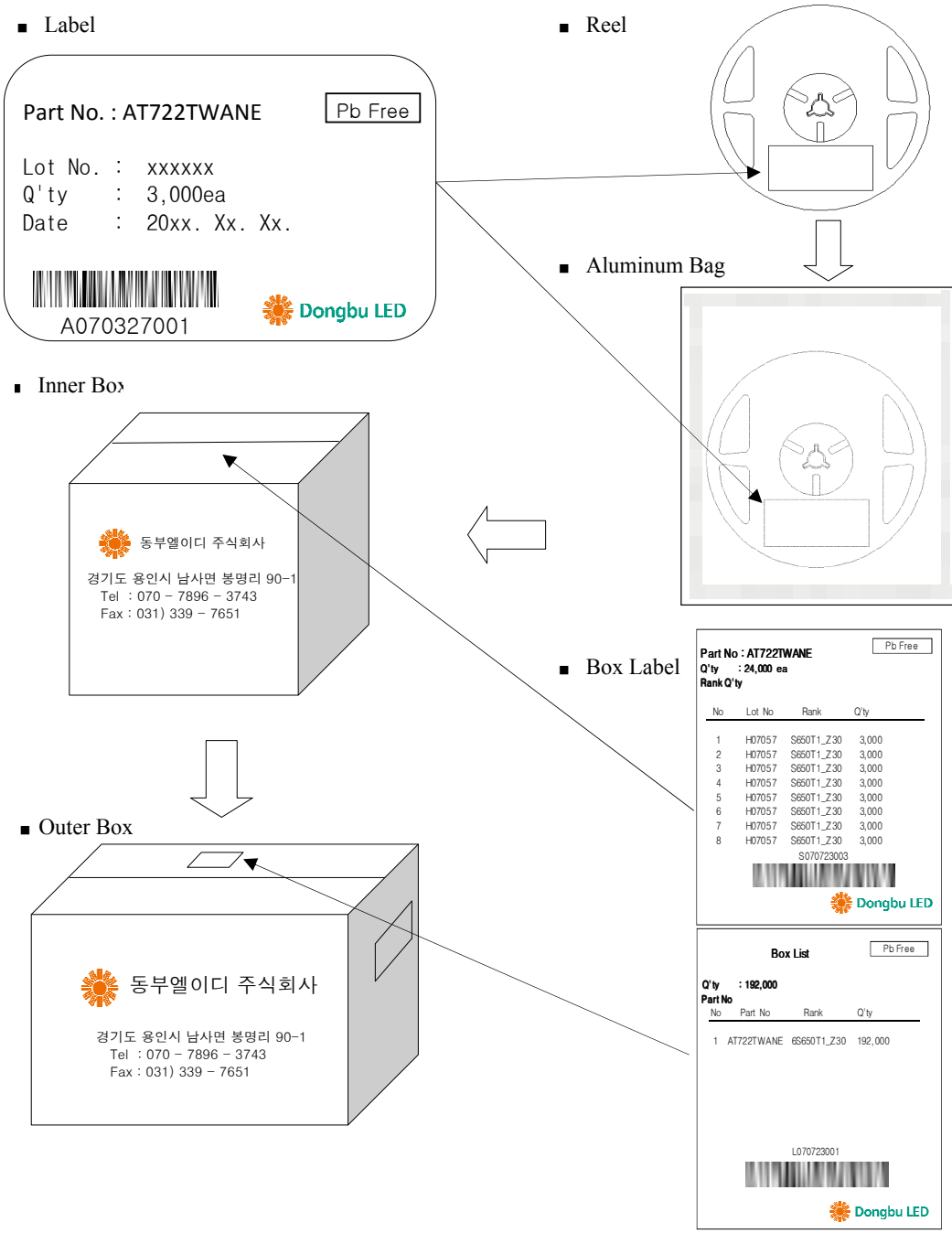

Box Type	Inner Box	Outer Box	
		Medium	Large
Max. Packing Q'ty(pcs)	24,000	96,000	192,000

(1) The carrier tape wound on the reel is placed into an ESD protected pack with a silicagel and sealed by the thermal pressure sealer. Then this sealed pack is packaged in a cardboard box.

## 6. Precaution

### (1) Static Electricity

These LEDs are highly susceptible to static electricity or surge voltage. So a wrist strap or an anti-electrostatic glove necessarily be used when handling the LEDs. Do not use the equipment that surge voltage is came into existence.

All devices and equipment that measure or mount the LEDs must be properly grounded.

After being assembled LEDs, it should be ascertained a electrical characteristic whether that are damaged by static electricity or not. It is easy to find the damaged LEDs by a light-on or VF test at forward a below 1mA current.

### (2) Packing

The moisture that is absorbed into the LED products may cause a badness and damage to the optical characteristics of the LEDs. Therefore the moisture barrier aluminum bag is used to keep moisture in the packing. And a silicagel is inserted into a moisture barrier aluminum bag that sealed by the thermal pressure sealer.

### (3) Cleaning

It is recommended that isopropyl alcohol(IPA) be used as a solvent for cleaning the LEDs.

Do not clean the LEDs by the ultrasonic. When it use other solvents or is absolutely necessary ultrasonic, before cleaning, a pre-test should be done to confirm whether the LEDs are any damaged or not

### (4) Storage

In order to avoid the absorption of moisture, it is recommended to store LEDs in the moisture barrier aluminum bag is not opened.

Storage condition before opening the packing :

Temperature : below 30℃

Humidity : 90%RH max

The LEDs should be used within a year.

Storage condition after opening the packing :

Temperature : below 30℃

Humidity : 60%RH max

After opening the packing, the LEDs should be used within 168 hours(7days). If unused LEDs remain, they should be stored in the place kept away moisture.

If the LEDs have exceeded the above storage time, it should be used after to bake using the following conditions.

Baking condition : 60±5℃, more than 24 hours

**(5) Pick and Place**

It should be avoided to rub or scratch the surface of resin by any hard material. It is possible that the LEDs are damaged to the optical characteristics.

**(6) Heat**

The LEDs are products that are generated heat. Please consider the heat generation of the LED when it is designed the PCB. After considering the ambient temperature and the heat generation of LEDs, the operating current should be decided

**(7) Others**

If the forward or reverse voltage which exceeds the absolute maximum rating is applied to the LEDs, that will cause the damage to the LEDs. It is possible that the damaged LEDs do not light on at the low current.

Be careful not to look the LEDs that the output power is strongly increased in the face. It is possible that eyesight has been getting weaker.

This specifications of the product may be revised without notice.